

ROKAE

xMate CR7-C

Hardware Installation Manual



A Partner You can Rely on in Production

xMate CR7-C

Hardware Installation Manual

Document ID: DOC- 00001751

Version: A

Copyright © ROKAE 2015-2024. All rights reserved.

Contents in this manual are subject to change without notice. We assume no responsibility for any errors that may appear in this manual.

Please understand that in no event shall we be liable for incidental or consequential damages arising from the use of this manual and the products described herein.

We cannot foresee all possible dangers and consequences. Therefore, this manual cannot warn the user of all possible hazards.

No part of this manual may be reproduced in any form.

If you find the contents of this manual wrong or in need of improvement or supplement, please contact us for correction.

This manual is originally written in Simplified Chinese, and other language versions are translated.

Copyright © ROKAE 2015-2024. All rights reserved.
Rokae (Shandong) Intelligent Technology Co., Ltd.
Shandong, China

Contents

| | |
|--|----------|
| 1 Manual Overview | 1 |
| 1.1 About this manual | 1 |
| 1.2 Target group | 1 |
| 1.3 How to read this manual | 1 |
| 1.4 Illustrations in this manual | 1 |
| 1.5 Related product documents | 1 |
| 1.6 Contact | 1 |
| 2 Safety | 2 |
| 2.1 Introduction | 2 |
| 2.1.1 Safety responsibilities | 2 |
| 2.1.2 Intended use | 2 |
| 2.2 Safety notice | 3 |
| 2.3 Safety protection device | 3 |
| 2.3.1 Emergency stop | 3 |
| 2.3.2 Enabling device | 3 |
| 2.4 Safety precautions | 4 |
| 2.4.1 Operator safety | 4 |
| 2.4.2 Safety precautions for operating the Teach Pendant | 5 |
| 2.4.3 Recovering from emergency stops | 5 |
| 2.4.4 Safety precautions in Manual mode | 6 |
| 2.4.5 Safety precautions in Automatic mode | 6 |
| 2.4.6 Safe handling of fire accidents | 7 |
| 2.4.7 Safe handling of electric shock accidents | 7 |
| 2.5 Personnel and work requirements | 8 |
| 2.5.1 Definition of personnel | 8 |
| 2.5.2 Personnel requirements | 8 |
| 2.5.3 Work requirements | 9 |
| 2.6 Safety training | 10 |

2.6.1 Overview 10

2.6.2 Personnel safety10

2.7 Pre-use assessment 11

3 Product Overview12

3.1 System structure 12

3.2 Manipulator 12

3.3 Teach Pendant 13

 3.3.1 Teach Pendant overview13

 3.3.2 Teach Pendant structure 14

 3.3.3 Holding of the Teach Pendant 14

3.4 Control cab 14

 3.4.1 Control cab overview 14

 3.4.2 Control cab structure 15

3.5 Symbols and labels 15

4 Technical Specifications16

4.1 Manipulator 16

 4.1.1 Basic parameters 16

 4.1.2 Working space 17

 4.1.3 Allowable load18

4.2 Teach Pendant 19

4.3 Control cab20

5 Unpacking and Installation21

5.1 Installation flow chart 21

5.2 Environmental conditions 21

5.3 Unpacking22

5.4 Transportation and handling 23

 5.4.1 Robot angle and force application points during transportation 23

 5.4.2 Handling 24

5.5 Installation 25

| | |
|--|-----------|
| 5.5.1 Inspection before installation | 25 |
| 5.5.2 Installation of robot and control cab | 26 |
| 5.5.3 Flange | 28 |
| 6 Electrical connection | 29 |
| 6.1 Control cab port | 29 |
| 6.1.1 Panel port | 29 |
| 6.1.2 External port | 30 |
| 6.2 Description of EOAT I/O ports | 37 |
| 6.2.1 Special-purpose EOAT I/O | 38 |
| 6.2.2 EOAT power output | 38 |
| 6.2.3 EOAT digital outputs | 38 |
| 6.2.4 EOAT digital inputs | 40 |
| 6.2.5 EOAT analog inputs | 40 |
| 6.2.6 EOAT communication | 41 |
| 6.3 Connection system | 42 |
| 6.3.1 Connection of the Teach Pendant | 43 |
| 6.3.2 Connection of the manipulator | 43 |
| 6.3.3 Connection of the control cab power supply | 44 |
| 6.3.4 Custom wiring | 44 |
| 6.3.5 Grounding instructions | 45 |
| 7 Quick Operation | 46 |
| 7.1 Power on | 46 |
| 7.2 Confirmation of the emergency stop | 46 |
| 7.3 Programming and usage | 46 |
| 8 Maintenance | 47 |
| 8.1 Introduction | 47 |
| 8.2 Maintenance safety | 47 |
| 8.3 Maintenance schedule | 47 |
| 8.4 Inspection | 47 |

| | |
|--|-----------|
| 8.5 Cleaning | 48 |
| 9 Zero Calibration | 49 |
| 9.1 What is a mechanical zero? | 49 |
| 9.2 What is zero calibration? | 49 |
| 9.3 When is zero calibration required? | 49 |
| 9.4 Zero calibration procedures | 49 |
| 10 Decommissioning | 51 |
| 10.1 Robot decommissioning | 51 |
| 10.2 Recycling | 51 |
| 11 Revision History | 52 |

1 Manual Overview

1.1 About this manual

Thank you for choosing ROKAE robot system.

This manual contains the following instructions for the correct installation and use of the robot:

- Mechanical and electrical installation of the robot.
- Maintenance and calibration of the robot.

Please read this manual and other related manuals carefully before installing and using the robot system.

After reading, keep it properly for future reference.

1.2 Target group

This manual is intended for:

- Installation personnel.
- Maintenance personnel.

Please ensure that the above personnel have the necessary knowledge of mechanical and electrical installation and maintenance, and have received our training.

1.3 How to read this manual

This manual includes a separate safety section that must be read through before proceeding with any installation or maintenance procedures.

1.4 Illustrations in this manual

Due to product upgrades or other reasons, some figures in this manual may differ from the actual product. However, the operating procedures are correct.

Also, figures from other models may be used to describe some general information.

1.5 Related product documents

This document is the manual for the xMate CR7-C robot and is intended to be used with the following documents:

- *xCore Robot Control System User Manual*

1.6 Contact

For information about the maintenance and repair of the robot, please contact our after-sales department or the local dealer.

Get the following information ready before contacting us:

- Robot model/serial number;
- Software name/version;
- Problems with the system.

2 Safety

2.1 Introduction

This section describes the principles and procedures that must be followed to ensure the safe use of xMate CR7-C robots. Robot integrators must read and understand the information listed here before powering on the robot for the first time.

The contents related to the design and installation of the external safety protection devices of the robot are not covered in this section. Please contact your system integrator to obtain such information.

2.1.1 Safety responsibilities

ROKAE is dedicated to but not liable for providing reliable safety information. Even if all safety instructions are followed, there is no guarantee that xMate CR7-C robots will not cause any personal injury or property damage.

In addition to the safety section, this manual contains further safety instructions.

2.1.2 Intended use

xMate CR7-C robots shall be used in accordance with local laws and regulations, and shall not be used for any purpose that violates such laws and regulations.

Using the robots in compliance with instructions also means observing the instructions in the manual of each component, including the operation, installation, and maintenance instructions.

The following uses that go against the instructions are prohibited:

- Use in human and animal transportation
- Use in potentially explosive environments
- Use in flammable environments
- Use outside the permissible limits
- Use underground

xMate CR7-C robots are flexible collaborative robots intended to handle EOAT/end effectors and fixtures or to process or transfer components or products. xMate CR7-C robots have special safety-related features, which are purposely designed to enable collaborative operation, where the robot system operates without fences and/or together with a human.

Collaborative operation is only intended for non-hazardous applications, where the complete application, including the EOAT/end effectors, workpieces, obstacles, and other machines, has no any significant hazards according to the risk assessment of the specific application.

Any purpose deviating from the intended use is deemed to be impermissible misuse, including but not limited to:

- Use in potentially explosive environments
- Use in medical and life-critical applications
- Use without a risk assessment
- Use outside the stated specifications
- Use as a climbing aid
- Use outside the permissible operating parameters

2.2 Safety notice

- A risk assessment must be conducted before operating or controlling the robot, and the robot must be used according to the safety instructions described in this manual.
- If you are unsure about the risks during the use of the robot, please contact ROKAE Technical Support. However, problems arising from non-intended use are not covered by our support.

2.3 Safety protection device

2.3.1 Emergency stop

Emergency stop is given the highest priority in the robot system. Pressing the emergency stop button will trigger the emergency stop. Then, all the functions will be frozen immediately, the robot will stop running, and the power of each joint will be cut off. The control system will be switched into the emergency stop state, which will be maintained before releasing the emergency stop button manually.

To resume the operation, it is required to release the emergency stop button first and then press the reset button on HMI for the motor of each joint to execute the power-on command.

The emergency stop button is located in the upper right corner of the Teach Pendant, as shown in 3.3.2.



Notes

Emergency stop should not be used for normal stops. Otherwise, it may cause extra and unnecessary wear to the brake and transmission system, which will eventually reduce the robot's lifespan.

There are two types of stops for robots according to ISO 13850 and IEC 60204 safety standards:

- STOP0: The motor power is switched off and the brakes are engaged;
- STOP1: The robot comes to a controlled stop. Then the motor power is switched off and the brakes are engaged.

After the emergency stop button on the Teach Pendant is pressed, the stop is enabled in type of STOP0.

2.3.2 Enabling device

The enabling device is a special switch with two contacts and three positions, so it is also called a three-position enabling switch (hereinafter referred to as "enabling switch"). It is used to power on/off the joints in Manual mode to enable robot motions.

The motor power is switched on only when the enabling switch is pressed and kept in the middle so that the robot is in a state ready for motion.

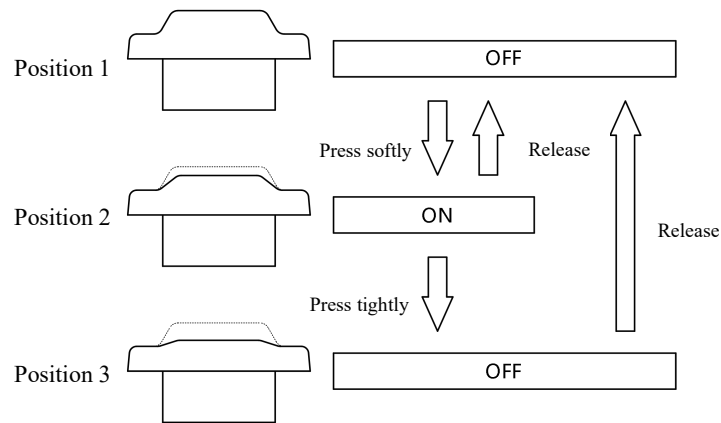

The enabling switch is located on the back of the Teach Pendant, as shown in 3.3.2.



Notes

When the enabling switch is pressed and held in the middle position in Manual mode, the robot will be powered on and enabled, the system will enter the Motor On state, and you can jog the robot or execute a program. The robot will be powered off, and the system will return to the Motor Off state when the switch is released or pressed all the way down.

To ensure the safe use of the robot, the following requirements must be observed:

The enabling switch shall function properly in any circumstances.

The enabling switch shall be released immediately when no robot motion is required during programming or debugging.

Any person who enters the robot's working space must carry a handheld enabling device to prevent others from starting the robot without the knowledge of the involved personnel.



Warning

It is strictly prohibited to use external devices to hold the enabling switch in the middle position.

2.4 Safety precautions

2.4.1 Operator safety

A few simple principles shall be followed in order to operate the robot safely:

- Always operate the robot in Manual mode if personnel are inside the safeguarded space.
- Always bring the handheld emergency stop device along when you enter the safeguarded space so that robot control is in your hands.
- Watch out for rotating or moving tools installed on the robot. Make sure those tools are stopped before you approach the robot.
- Watch out for grippers and objects gripped. If the gripper is opened, the workpiece could fall and cause personal injury or equipment damage. The gripper can be very powerful and can also cause injuries if not operated in a safe manner.

2.4.2 Safety precautions for operating the Teach Pendant

2.4.2.1 Safe storage of the Teach Pendant

The Teach Pendant no longer used shall be properly stored in a place where is far away from the robot workstation, so as to prevent the operator from mistakenly believing that this Teach Pendant is still connected to the robot and attempting to use it to stop the robot in case of danger.

2.4.2.2 Teach pendant cable

The Teach Pendant and control cab are connected through a Teach Pendant cable. The following provisions shall be observed when using the Teach Pendant in order to avoid personal injury or equipment damage:

- Make sure that the working personnel does not stumble over the Teach Pendant cable so as to avoid dropping the Teach Pendant or making personnel fall.
- Don't squeeze the Teach Pendant cable, otherwise, its internal cores may be damaged.
- Don't put the Teach Pendant cable on the edge of the sharp objects, otherwise, the cable sheath may be damaged.
- Make sure that the bending radius of the Teach Pendant cable is greater than 100 mm, otherwise, the cable may be damaged.

2.4.2.3 Permission of using the Teach Pendant

Generally, only those who have completed safety training and basic operation training can have permission to use the Teach Pendant. The user permissions for operating the Teach Pendant interface shall also be distinguished to ensure that the debugging personnel and maintenance personnel can use the Teach Pendant correctly and reasonably according to their work.

The control system is built-in with three user levels, namely Operator, Admin, and God, with the operation permissions ranking from low to high. Switching from a low-privileged user to a high-privileged user requires a password. Conversely, it is not required. A high-privileged user can modify the password of a same- or lower-privileged user. The password of an Operator-level user cannot be modified.

2.4.2.4 No Teach Pendant mode

When the No Teach Pendant mode is selected for the control system, special attention must be paid to safety during debugging and programming. An emergency stop button must be installed or placed within the reach of the operator and the signal of the emergency stop button must be routed into the safe I/O port of the robot system so that the person can protect the safety of himself/herself and the equipment by pressing the emergency stop button promptly in case of emergencies.

2.4.3 Recovering from emergency stops

2.4.3.1 Description

In case of an emergency stop, a reset is required to return to normal operation. The reset procedure is simple but important. It ensures that the robot system is prevented from returning to production in a hazardous condition.

2.4.3.2 Emergency stop button and reset

The emergency stop button is located in the upper right corner of the Teach Pendant. It has a latching feature that must be manually released in order to remove the emergency stop condition of the robot. This can be done by rotating the button as marked.

2.4.4 Safety precautions in Manual mode

2.4.4.1 About the Manual mode

In Manual mode, the robot's movement is under manual control. You can jog the robot or execute a program only when the enabling switch is held in the middle position. The enabling switch is located on the handle of the Teach Pendant.

The Manual mode is used during programming and debugging of the robot, as well as commissioning of the workstation.

2.4.4.2 Speed limit in Manual mode

In Manual mode, the speed of the robot's end effector is limited to below 250 mm/s, that is, the maximum speed of the robot will not exceed 250 mm/s whether you jog the robot or execute a program, regardless of the speed set in the program.

2.4.4.3 Bypassing external safety signals

In Manual mode, signals of external safety devices such as the safety gate and safety grating will be bypassed. This means that the emergency stop will not be triggered in Manual mode even if the safety gate is open, which facilitates the debugging.

2.4.5 Safety precautions in Automatic mode

2.4.5.1 About the Automatic mode

The Automatic mode is used for running the robot program in production.

In Automatic mode, the enabling switch will be bypassed so that the robot can run automatically without manual intervention.



Danger

In Automatic mode, the robot moves at the speed set in the program, which is up to 3.2 m/s for the end effector. In this mode, personnel must not enter the working space of the robot to avoid personal injury.

2.4.5.2 Enabling external safety signals

External safety devices such as the safety gate and safety grating will be enabled in Automatic mode. Opening the safety gate will trigger an emergency stop.

2.4.5.3 Safe troubleshooting in production

In most cases, the robot is part of the production line. Therefore, the impact of a robot fault may go beyond the workstation itself. Likewise, problems with other parts of the production line may also impact the workstation. For this reason, a remedy plan shall be prepared by personnel who are familiar with the entire production line to improve safety.

- Pay attention to other running devices around the robot

For example, a robot on the production line grabs workpieces from the conveyor belt. When the robot has a fault, the robot maintenance personnel shall consider additional safety measures for working beside the moving conveyor belt to ensure uninterrupted production while the robot is under repair.

- Pay attention to other devices that interact with the robot

For another example, when removing a welding robot from the production line for routine maintenance, the robot supplying materials to it must also be stopped to avoid personal injury.

2.4.6 Safe handling of fire accidents

2.4.6.1 Handling of mild fires

It is required to keep calm when a fire hazard is imminent or has not yet begun to spread. You can use on-site fire-extinguishing devices to put out the flame. It is strictly prohibited to use water to put out a fire caused by short circuits.



Warning

The fire-extinguishing device on the working space of the robot shall be supplied by the user, and the user shall choose an appropriate fire-extinguishing device according to the actual situations. For fire with the controller, a carbon dioxide (CO₂) fire extinguisher is required.

2.4.6.2 Handling of severe fires

If the fire has spread beyond control, the workers on site shall notify other workers immediately to give up their personal belongings and evacuate immediately through emergency exits rather than try to put out the fire. Do not use an elevator, and inform the fire department during evacuation.

If a person's clothing catches fire, prevent him/her from running but let him/her lie flat on the ground immediately. Put out the fire using clothes or other suitable items and methods.

2.4.7 Safe handling of electric shock accidents

2.4.7.1 Handling of electric shocks

When someone gets an electric shock, it is required to keep calm and cut off the power supply immediately. Appropriate methods and measures shall be adopted without hesitation according to the site conditions:

- If the power switch or button is very near to the location of the electric shock, switch it off to cut off the power supply.
- If the power switch or button is far away from the location of the electric shock, use insulated pliers or ax, knife, and shovel with dry wooden handles to cut off live wires on the mains' side (power supply), and keep the separated wire from contacting with the human body.
- If the conducting wire is over or under the body of the injured, use a dry stick, board, bamboo pole, or other tools with insulated handles (by gripping the insulated handle) to remove the wire. Do not use metal bar or wet object to avoid the rescuer from also getting an electric shock.



Warning

The rescuer shall not be in direct contact with the electrically shocked person. Otherwise, they may also get an electric shock.

2.4.7.2 Treatment of the injured after being separated from the power source

- If the injured is conscious, make him/her lie on the back and watch him/her out to prevent from standing or walking for the time being.
- If the injured is unconscious, make him/her lie on the back to keep the airway open. Call the injured or pat him/her on the shoulder at an interval of 5s to judge if he/she lose consciousness. Do not call the injured by shaking his/her head. Meanwhile, contact the hospital as soon as possible.

- If the injured loses consciousness, confirm his/her respiratory conditions and heartbeat within 10s. If neither breath nor arterial pulse is sensed, the injured may have a cardiac arrest. Then, give him/her immediate first aid treatment by cardiopulmonary resuscitation.

2.5 Personnel and work requirements

2.5.1 Definition of personnel

There are three types of personnel:

- Operators

The operators can switch on/off the robot power supply and start robot programs through the Teach Pendant or other interfaces.

- Debugging personnel

The debugging personnel can conduct robot operations, enter into the safeguarded space, and perform operations such as setting, teaching, and programming on the robot.

- Maintenance personnel

The maintenance personnel can conduct robot operations, enter the safeguarded space, perform operations such as setting and teaching on the robot, as well as adjust and repair the robot.



Warning

The debugging and maintenance personnel who can enter the safeguarded space must accept and pass professional robot training in advance.



Warning

When performing robot operations, programming, and maintenance, personnel must pay attention to safety and wear necessary protective equipment, including work clothes, safety shoes, and safety helmets suitable for the work according to the actual conditions.

2.5.2 Personnel requirements

2.5.2.1 Operator requirements

The operator shall meet the following requirements:

- The age of the operator shall fall within the age range specified in local employment laws.
- The operator shall be in good physical condition. A good physical condition means good vision (glasses and contact lenses are allowed), good hearing, and good coordination ability. The operator may not intake substances that may reduce their mental level (such as medicines, alcohol, and drugs) during work.
- The operator shall understand applicable local safety regulations, such as the work safety and health regulations and the industrial accident prevention regulations.

2.5.2.2 Debugging personnel requirements

The debugging personnel shall meet the criteria of operating personnel. In addition, the debugging personnel shall also meet the following conditions:

- The debugging personnel shall have basic technical knowledge, understand the

technical documents and drawings related to the robot, and be able to complete their tasks according to relevant documents.

- The debugging personnel must be very familiar with the robot system and be able to reasonably achieve the purpose by operating the robot according to actual needs.

2.5.2.3 Maintenance personnel requirements

In addition to compliance with the operator requirements, the maintenance personnel shall also have some other expertise (such as electrical, mechanical, and pneumatic) and be able to complete their tasks according to relevant documents.

2.5.3 Work requirements

2.5.3.1 Safety requirements for installation and operation

- Handle and install the robot equipment through the methods described in our manual. Otherwise, the robot may fall due to misoperation, thus leading to personal injury and death or equipment damage.
- When the robot equipment is put into use for the first time after installation, run it at low velocity first and then gradually increase the velocity rather than running at high velocity from the start.
- Note that by default, program and system information (including variables) is stored in the storage device at control cab. In order to prevent data loss caused by accidents, it is recommended that the user make data backups regularly.

2.5.3.2 Safety requirements for debugging

Debugging shall be carried out outside the safeguarded space as much as possible. When debugging must be carried out inside the safeguarded space, special attention shall be given to the following:

- Carefully check the condition of the safeguarded space and enter into it only after confirming no danger exists.
- Confirm the positions of all debugging personnel inside the safeguarded space.
- Confirm the status of the entire system before proceeding with the work.
- Make sure that the emergency stop button can be pressed whenever necessary.
- Run the robot at low velocity.

When debugging is finished, the debugging personnel must stay outside the safeguarded space.

2.5.3.3 Safety requirements for maintenance

- Carefully check the condition of the safeguarded space and enter into it only after confirming no danger exists.
- Confirm the positions of all maintenance personnel inside the safeguarded space.
- When the power supply is switched on, some maintenance operations may pose the danger of electric shock. Therefore, switch off the power supply of the robot equipment and system before carrying out the maintenance.
- During the maintenance, prevent other personnel from switching on the power supply accidentally.
- To avoid unnecessary personal injury or adverse impact on the equipment, do not place any part of your body on any position of the robot equipment during the operation.
- Provide appropriate lighting during the maintenance.
- In case of part replacement, make sure to use a part specified by ROKAE. Otherwise,

the robot equipment may be damaged.

- Install the parts removed during the replacement (such as screws) properly to their original positions. If you find the parts not enough or redundant, confirm again and make sure to install them correctly.

2.6 Safety training

2.6.1 Overview

The on-site operator, debugging personnel, and maintenance personnel must accept formal robot safety and operation training and pass the exams before they can perform operation, debugging, and maintenance on the robot. Operating, debugging, or maintaining robots by non-professional personnel or personnel who failed during the training is prohibited in order to avoid severe personal injury and damage to the robot equipment.

All the personnel of the equipment shall:

- Check the current condition of the equipment and ensure that no failure is present before performing operation and debugging on the robot equipment.
- Minimize life and property losses by choosing the safest method to handle emergency incidents as they occur.
- Fully understand relevant documents and work on the equipment according to the requirements of documents.

2.6.2 Personnel safety

The following general precautions must be noted to ensure personnel safety:

- When the equipment is running, even if the robot seems to have stopped, it may be waiting for the start signal to run. At this time, the equipment shall also be deemed as in the operating state.
- All peripheral equipment shall be well grounded.
- Peripheral equipment shall be installed outside the working range of the robot
- The motion range of the robot equipment shall be marked by drawing lines on the floor or other means.

2.6.2.1 Safety of operators

To ensure the safety of operators:

- Operate the robot outside the safeguarded space.
- Set up a protective fence or safety door in order to prevent irrelevant personnel from entering the safeguarded space.
- Switch off the power supply or press the emergency stop button in case of no operation on the robot.
- Install the emergency stop button within reach of the operator.

2.6.2.2 Safety of debugging personnel

During the debugging, you need to enter into the working range of the robot under some circumstances. To ensure the safety of debugging personnel:

- Make sure that the equipment is safe before debugging.
- Check the position and status of the safety devices (such as the emergency stop button) in advance.
- Prevent other personnel from entering the working range of the robot.
- Before starting the robot, make sure that there is no personnel in the working range of

the robot.

When the debugging is finished, a test run shall be performed according to the following procedures:

- At low velocity, execute the program one step after another for at least one cycle to confirm that everything is normal.
- At low velocity, execute the program continuously for at least one cycle to confirm that everything is normal.
- At the actual running velocity, execute the program continuously for at least one cycle to confirm that everything is normal.

2.6.2.3 Safety of maintenance personnel

To ensure the safety of maintenance personnel:

- Make sure that the peripheral equipment is safe before maintenance.
- Switch off the equipment power supply before maintenance. Lock the main circuit breaker using a lock as necessary in order to prevent other personnel from switching on the power supply accidentally.
- When you have to enter into the working range of the robot while the power is on, press the emergency stop button before entering. Put up a "Repairs in Progress" sign in order to prevent other personnel from operating the equipment accidentally.
- Do not enter into the working range of the robot while it is moving.
- Do not execute the automatic running of the program when there is other personnel within the working range of the robot.
- During maintenance, assign a person who is familiar with the robot system and is able to sense dangers near the equipment to press the emergency stop button in case of an emergency.
- During component replacement or reassembly, avoid the adhesion or inclusion of foreign objects.
- For maintaining the interior of the robot, if it is necessary to touch the power supply unit or printed circuit board, switch off the power supply of the robot in advance to prevent electric shock.

2.7 Pre-use assessment

The following tests must be conducted before using the robot for the first time or after making any modifications to verify that all safety inputs and outputs are correct and properly connected, and check whether all connected safety inputs and outputs are functioning properly, including:

- Test whether the emergency stop button on the Teach Pendant can be enabled to stop the robot and engage the brakes.
- Test whether the robot can be switched between Manual and Automatic modes.
- Test whether the motion can be enabled in Manual mode only with enabling switch pressed and the robot is under deceleration control.

3 Product Overview

3.1 System structure

The xMate CR7-C robot is a new flexible collaborative robot that boosts increased industrial productivity with highly sensitive force sensing and highly dynamic force control. It consists of the manipulator, control cab, Teach Pendant, relay cable, power cable, control system software, etc.

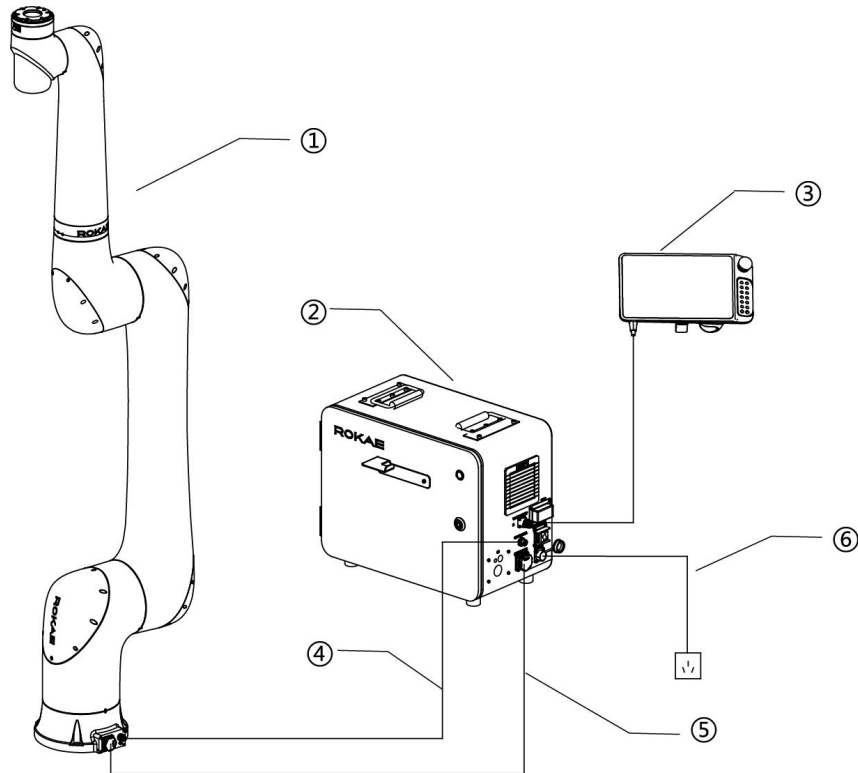

| S/N | Name |
|-----|-------------------------|
| 1 | Manipulator |
| 2 | Control cab |
| 3 | Teach Pendant |
| 4 | Signal relay cable |
| 5 | Power relay cable |
| 6 | Control cab power cable |

3.2 Manipulator

The xMate CR7-C flexible collaborative robot manipulator features 6 degrees of freedom, that is, 6 joints or axes. The definitions of axis rotation directions and coordinate systems are described below.

Base coordinate system: The -X axis refers to the outgoing cable direction of the base, and the +Z axis refers to an upward direction perpendicular to the mounting surface. The Y axis is determined by the right-hand rule.

Flange coordinate system: When the robot is in the zero position, the +Z axis refers to an outward direction perpendicular to the flange surface, and the +X axis refers to the

direction opposite to outgoing cable direction of the base. The Y axis is determined by the right-hand rule.

Rotation axis directions: When the axes are in the zero position, the A1, A4, and A6 perform forward rotation in the +Z direction of the base coordinate system, the A2 performs forward rotation in the +Y direction, and the A3 and A5 perform forward rotation in the -Y direction.

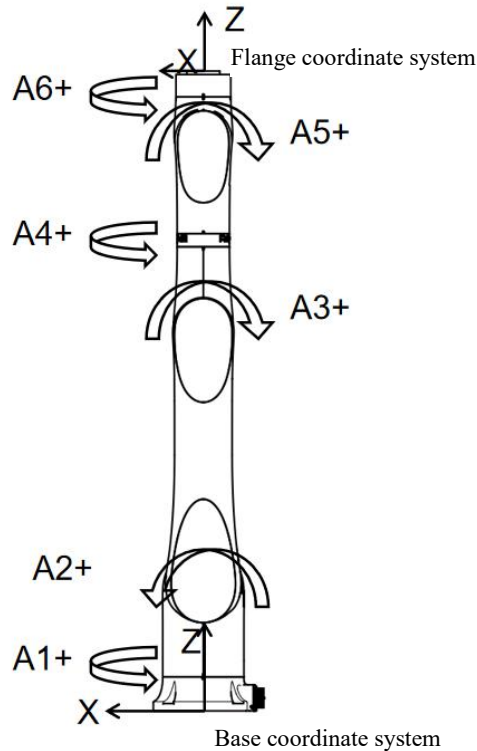

3.3 Teach Pendant

3.3.1 Teach Pendant overview

The Teach Pendant is an embedded handheld device integrated with complete hardware and software. It is available for performing all robot-related functions, including programming and debugging, viewing system status, and setting system parameters.

The robot system is equipped with a Teach Pendant called xPad2, which is well-designed, reliable, and easy to use. Skilled use of xPad2 will greatly improve the efficiency of the robot.

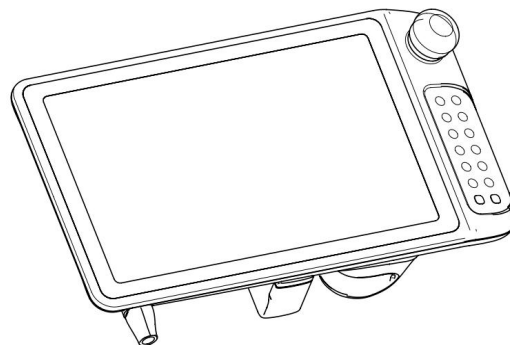

3.3.2 Teach Pendant structure

The xPad2 Teach Pendant consists of the following components:

- Capacitive touch screen
- Button
- Emergency stop button
- Three-position enabling switch
- USB port, etc.

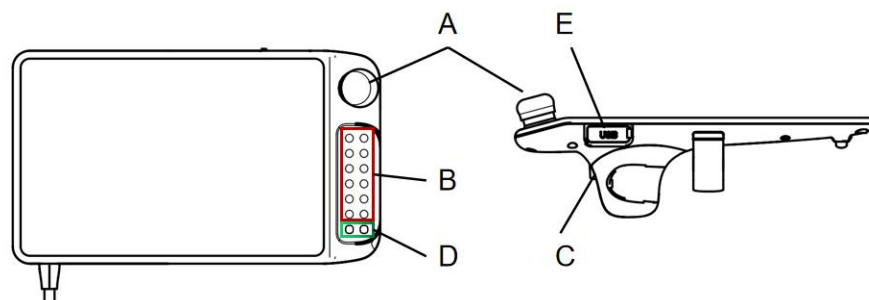

| S/N | Description |
|-----|---|
| A | Emergency stop button: used to trigger an emergency stop in case of danger. |
| B | Jog buttons: refer to 12 buttons in 6 groups corresponding to the robot's 6 joints or 6 DOF in Cartesian space. |
| C | Three-position enabling switch: used to enable robot motion in the Manual mode. |
| D | Function buttons: used to scroll between functions displayed on the touch screen. |
| E | USB port: used for connecting the USB drive and protected with a rubber cover. |

3.3.3 Holding of the Teach Pendant

The Teach Pendant is usually used for handheld operation. Right-hand users are required to hold the Teach Pendant with left hand and operate the buttons and touch screen with right hand, as shown in the figure below:

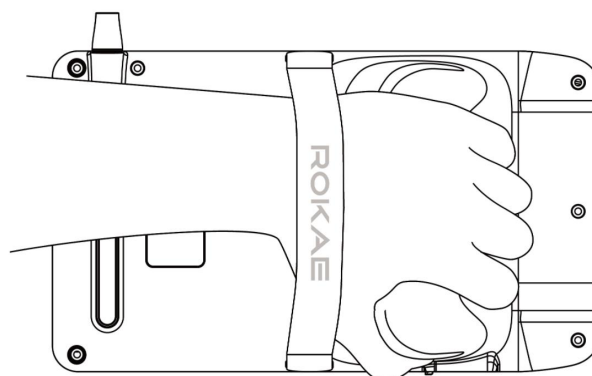

3.4 Control cab

3.4.1 Control cab overview

The main components of the robot control system are installed in a xMate control cab (MCC), as shown in the figure below:

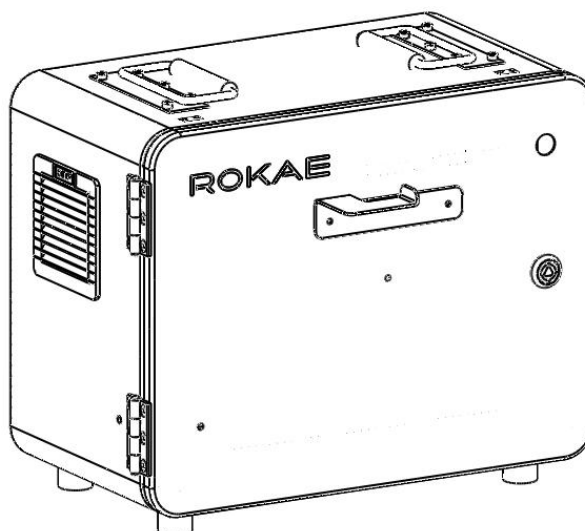

3.4.2 Control cab structure

The MCC is designed to accommodate all the necessary components for controlling the robot's movements, as shown in 6.1.

3.5 Symbols and labels

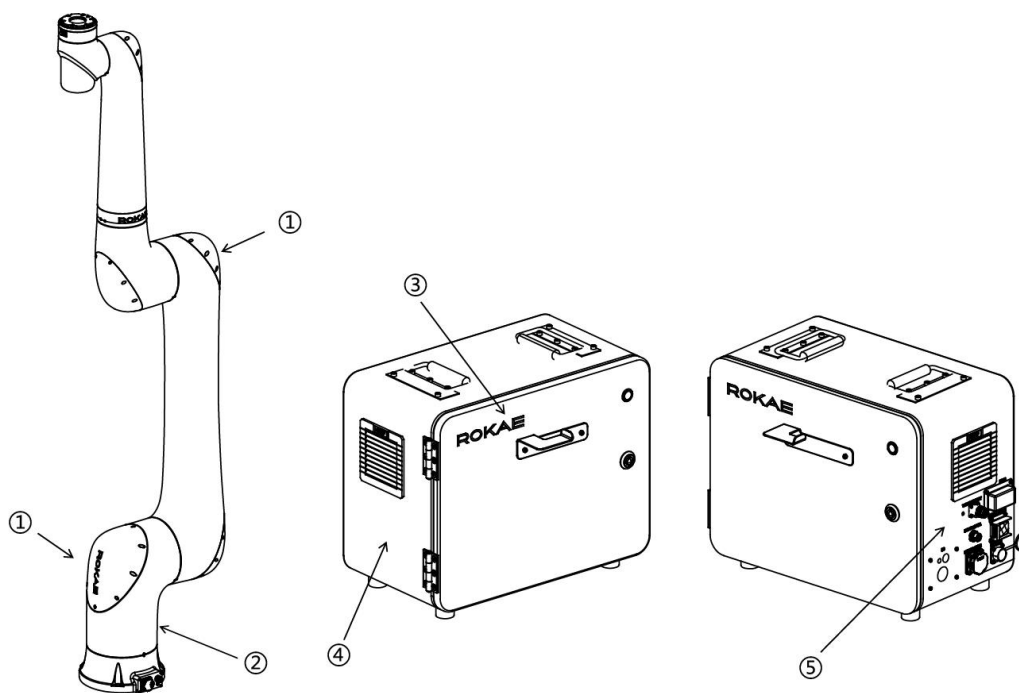

| S/N | Item |
|-----|--------------------------|
| 1 | Manipulator logo |
| 2 | Manipulator nameplate |
| 3 | Control cab logo |
| 4 | Control cab nameplate |
| 5 | Electrical hazard symbol |

4 Technical Specifications

This section describes the specifications of xMate CR7-C flexible collaborative robots.

4.1 Manipulator

4.1.1 Basic parameters

| Item | Parameter | |
|---|--------------------------------|--------|
| Product Name | xMate CR7-C | |
| Number of axes | 6 | |
| Maximum reach | 988mm | |
| Repeatability | ±0.02mm | |
| Maximum payload | 7kg | |
| Range of motion | Axis 1 | ±360° |
| | Axis 2 | ±360° |
| | Axis 3 | ±360° |
| | Axis 4 | ±360° |
| | Axis 5 | ±360° |
| | Axis 6 | ±360° |
| Maximum speed | Axis 1 | 180°/s |
| | Axis 2 | 180°/s |
| | Axis 3 | 234°/s |
| | Axis 4 | 240°/s |
| | Axis 5 | 240°/s |
| | Axis 6 | 240°/s |
| Operating temperature | 0°C ~ +50°C | |
| Storage temperature | -10°C ~ +55°C | |
| Maximum relative operating/storage humidity | 93%, non-condensing, non-frost | |
| IP rating | IP67 | |
| Mounting mode | At any angle | |
| Weight | 25 kg | |
| Noise (mean) | ≤70 dB(A) | |



Warning

When the equipment leaves the factory, the motion limit of each axis does not exceed ±180° by default. The user can modify the range of motion of each axis according to the actual situations and this manual, provided that:

- The user is clearly aware of the range of motion of each axis described in this manual.
- The user ensures that the modified limit does not exceed the range of motion described in this manual.
- The user comprehensively considers relevant factors such as robot installation modes, EOAT characteristics, surrounding environment, and ensures that the

- modified limit and the programming will not pose danger of collision.
- If the user changes the limit and brings it into effect, it means that the user confirms that the above rules are followed properly, and agrees that all consequences arising from the failure to follow the above rules properly will be borne by the user.

4.1.2 Working space

xMate CR7-C workspace diagram – the space went by the wrist reference point (the intersection of axes 4 and 5), as shown in the figure below.

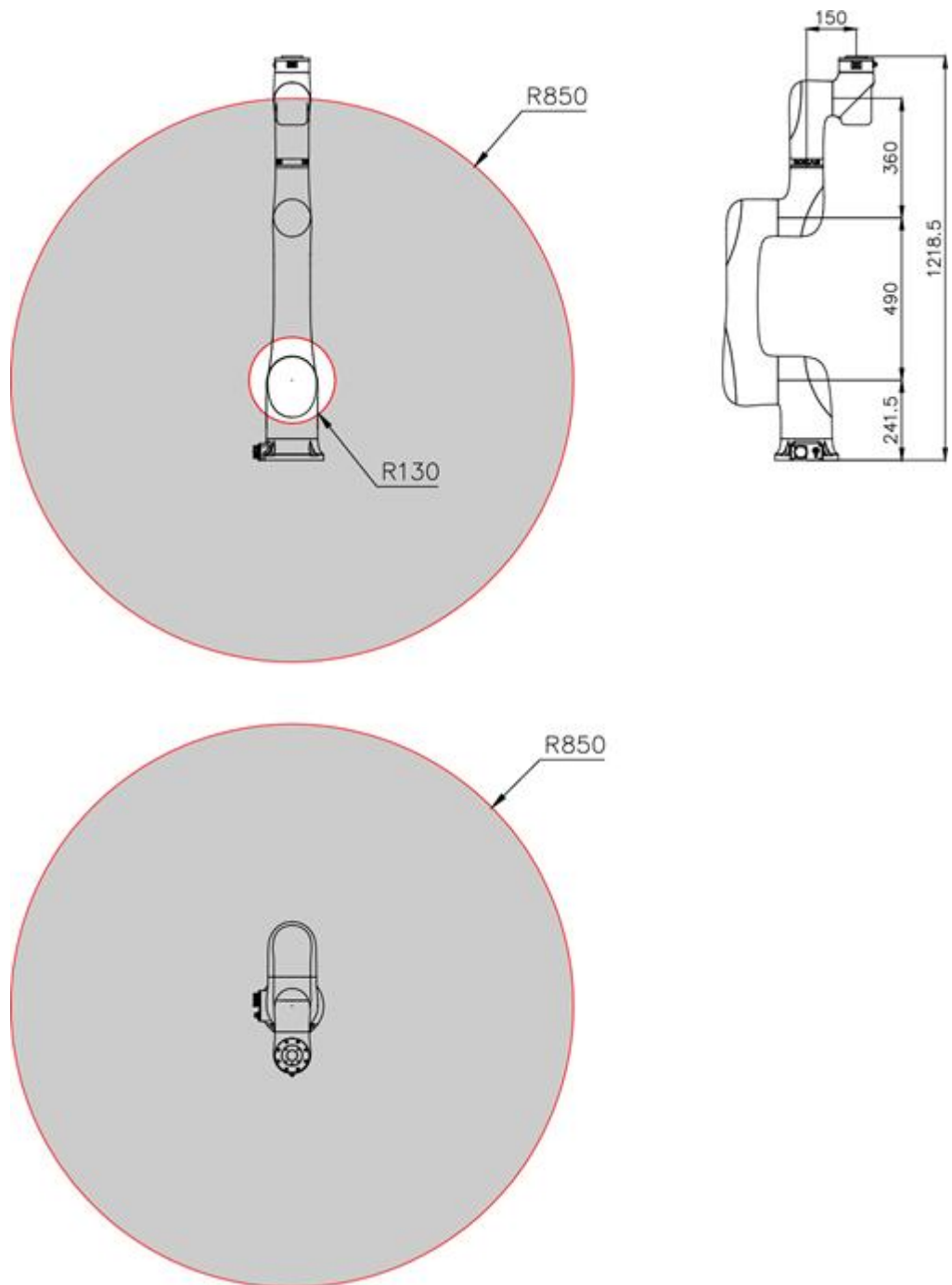

4.1.3 Allowable load



Warning

It is very important to always define the actual load correctly and calibrate the payload of the robot. Otherwise, it may result in robot overload.

If incorrect load and/or load other than those specified in the load diagram are used, the following components may be damaged due to overload:

- Motor
- Reducer
- Mechanical structure

All loads installed on the robot, including the total weight of the end effector, fixture, and workpiece, shall be less than the maximum payload of the robot.

Robots operating with incorrect load and/or load other than those specified in the load diagram will not be covered by the robot warranty.

4.1.3.1 Allowable wrist torque and inertia

The allowable torque and inertia of xMate CR7-C robots are shown in the table below:

| Axis | Allowable Torque (N.m) | Allowable Inertia (kg·m ²) |
|--------|------------------------|--|
| Axis 4 | 24.6 | 1.56 |
| Axis 5 | 28.6 | 1.62 |
| Axis 6 | 30.0 | 1.63 |



Warning

The payload must not exceed the allowable torque and inertia!

It is required to match the load according to the robot's carrying capacity. The load beyond the carrying capacity of the robot will trigger the alarm or even cause damage to robot components, thereby reducing the robot's service life.

4.1.3.2 Maximum payload diagram

The center-of-gravity position of the load is determined by the distance between the load center and the flange surface, where L_{xy} represents the distance between the load center and the axis A6 and L_z represents the distance between the load center and the flange mounting surface. The distance corresponding to different loads is shown in the following diagram.

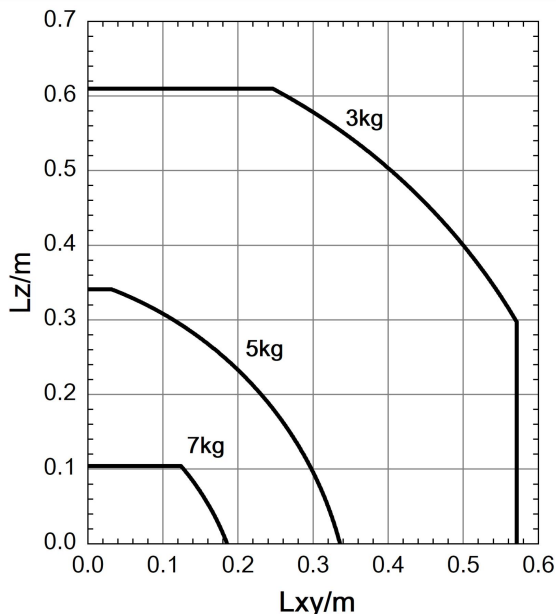

 **Warning**

When calculating the load weight, the weight of the end effector shall be included, and the load requirements shall be met. In addition, the system shall never exceed the maximum payload.

4.1.3.3 Calculation of load and inertia

In order to achieve optimal robot performance, you must clearly confirm that the load (the weight of the end effector and workpiece) and the inertia are within the maximum allowable value. When installing the effector at the robot end, the effector's moment of inertia shall be taken into consideration.

 **Notes**

Generally, with an accurate 3D model, the mass, center of mass, and inertia of the load can be obtained quickly from the 3D CAD software!

4.1.3.4 Joint torque limit

Before actual application, joint torque must be taken into account in risk analysis. The following table shows the joint torque limits, which shall be observed during use. Otherwise, the robot may be damaged due to overload.

| Axis | Joint Torque Limit (N.m) |
|------|--------------------------|
| 1 | 194 |
| 2 | 194 |
| 3 | 102 |
| 4 | 60 |
| 5 | 60 |
| 6 | 60 |

4.2 Teach Pendant

| Item | Parameter |
|--------------|-----------|
| Product Name | xPad2 |

| | |
|---|--------------------------------|
| Screen size | 10.1" |
| Resolution | 1920×1200 |
| Trigger type | Capacitive |
| Dimensions | 290 mm×170 mm×80 mm |
| Weight | About 840 g (excluding cable) |
| Minimum cable bending radius | 50 mm |
| IP rating | IP54 |
| External port | USB 3.0 |
| Operating temperature | 0°C to +45°C |
| Storage temperature | -25°C to +55°C |
| Maximum relative operating/storage humidity | 90%, non-condensing, non-frost |

4.3 Control cab

| Item | | Parameter |
|---|-----------------------------|--|
| Product Name | | xMate Control Cab |
| Model | | MCC1024A |
| Safety integrity level | | ISO13849-1:2015, Cat 3, PL d |
| Mounting mode | | Floor mounting and back board fixing |
| Noise | | ≤70 dB |
| IP rating | | IP54 |
| Electrical connection | Power supply | Single phase, 90 VAC to 264 VAC, 47 Hz to 63 Hz |
| | Maximum output power | 2 kW |
| | Short-circuit current | 40 A |
| Operating temperature | | 0°C to +45°C |
| Storage temperature | | -25°C to +55°C |
| Maximum relative operating/storage humidity | | ≤95%, non-condensing, non-frost |
| Physical properties | Dimensions | 450 mm×250 mm×350 mm (L×W×H) |
| | Weight | About 14 kg |
| | Color | Grey & white |
| User port | General-purpose digital I/O | 16 inputs/16 outputs (standard), maximum 48 inputs/48 outputs (with optional components) |
| | Safety I/O | 5 safety inputs and 4 safety outputs in dual redundant channels |
| | Communication port | RS232 ×1 Ethernet port ×1 USB3.0 ×2 HDMI ×1 |
| | Fieldbus | EtherCAT ×1 |
| | Optional extended support | CC-Link communication module General-purpose digital I/O module Analog voltage/current I/O module Incremental encoder signal acquisition module |
| | DC output power | Voltage: 24 V DC Maximum current: 2A Short-circuit protection provided |

5 Unpacking and Installation

This section contains instructions for unpacking and installing the xMate CR7-C flexible collaborative robot.

5.1 Installation flow chart

The installation flow chart is used to check the robot installation progress. Put a check mark in the "Completed" column when a step is finished.

| Step | Operation | Completed |
|--|--|-----------|
| 1. Preparation before installation | | |
| ① | Installation personnel | |
| ② | Installation environment | |
| ③ | Installation foundation | |
| ④ | Support pillar | |
| 2. Confirmation of enough space for installation | | |
| 3. Unpacking and handling | | |
| ① | Unpacking | |
| ② | Checking the packing list | |
| ③ | Handling | |
| 4. Installation of manipulator | | |
| ① | Installing the robot in place | |
| 5. Cable connection | | |
| ① | Connecting the power and signal cables between the manipulator and the control cab | |
| ② | Connecting the control cab with the power socket with the power cable | |
| ③ | Connecting the Teach Pendant (if required) | |
| 6. User wires | | |
| ① | Connecting I/O signal cables (if required) | |



Notes

The user shall provide M8 hex wrench, unpacking tools, and necessary protective equipment such as gloves.

5.2 Environmental conditions

Robots are intended for use in general industrial environments and under working conditions of each component as specified in 0. The following conditions shall be met.

- Install indoor to avoid exposure to sunlight;
- Keep away from dust, metal powder, oil mist, salt mist, etc;
- Keep away from flammable and corrosive liquids and gases;
- Prevent water intrusion from all directions;
- Protect from shock and vibration;
- Operate at an altitude below 1,000 m;

- Keep away from sources of electrical interference;
- In addition:
- Ensure that the electrical fast transient (EFT) is below ± 2 kV;
 - Make sure the electrostatic discharge (ESD) is below ± 8 kV.

 **Warning**

It is prohibited to place or use the robot in any explosive environment.

 **Notes**

At low ambient temperature ($<10^{\circ}\text{C}$), the grease (or lubricating oil) inside the reducer (or gearbox) has a high viscosity and may cause the robot to stop or operate inefficiently. In this case, it is recommended to warm up the robot and other auxiliary equipment.

The environmental conditions under which the robot is stored shall conform to the storage conditions for each component as specified in 0.

5.3 Unpacking

The following unpacking tools are required:

- Utility knife/scissors $\times 1$;
- Protective gloves $\times 1$.

Wear protective gloves and cut open the package with scissors or utility knife. Then, you will find the following items in the box:

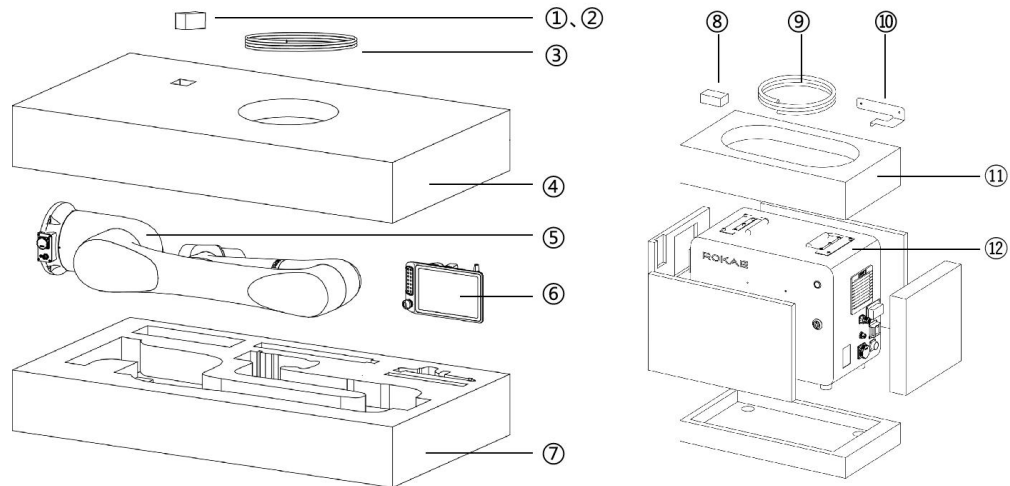

| S/N | Item | Model | Quantity | Remark |
|-----|-----------------------------------|--------------------|----------|-----------------------------------|
| 1 | USB flash drive | ROKAE 32G/PD095 | 1 | |
| | Mechanical zero calibration block | LS28-A0-101 | 1 | |
| | Hexagon socket head cap screw | M8x30 (Grade 12.9) | 4 | Used for manipulator installation |
| 2 | xMate CR7-C Hardware | | 1 | Stored on a USB |

| | | | | |
|----|---|---------------------------|---|--|
| | Installation Manual (Electronic Version) | | | flash drive |
| | xCore Robot Control System User Manual (Electronic Version) | | 1 | |
| 3 | External connecting cable for EOAT I/O port | | 1 | |
| | Power relay cable | | 1 | |
| | Signal relay cable | | 1 | |
| 4 | Top liner | | 1 | |
| 5 | xMate CR7-C | | 1 | |
| 6 | xPad2 Teach Pendant | | 1 | |
| 7 | Bottom liner | | 1 | |
| 8 | Control cab key | | 1 | |
| | Hexagon socket head cap screw | M4×8 (stainless steel) | 2 | Used for Teach Pendant hanger installation |
| 9 | Control cab power cable | | 1 | |
| 10 | Teach Pendant hanger | | 1 | |
| 11 | Control cab liner | | 1 | |
| 12 | Control cab | | 1 | |

Take out the parts from the box in order, keep them properly, and handle accessories such as USB flash drive, calibration block, control cab key, and cables with care.

| | |
|---|---|
|  | <p>Warning</p> <p>It is required to transport the robot together with the top and bottom liners after it is unpacked and before it is installed in place, and keep the robot balanced to prevent it from tipping over during transportation. In addition, the liners can only be removed when the manipulator is ready to install.</p> |
|---|---|

5.4 Transportation and handling

5.4.1 Robot angle and force application points during transportation

During transportation, the robot shall be at the posture shown in the following figure and shall be carried at the point indicated by the arrow in the following figure.

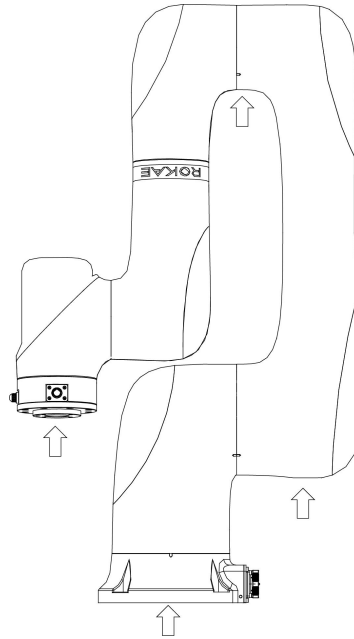

The angles of all axes during transportation are as follows:

| Axis 1 | Axis 2 | Axis 3 | Axis 4 | Axis 5 | Axis 6 |
|--------|--------|--------|--------|--------|--------|
| 90° | 0° | 175° | 0° | 0° | 0° |



Warning

The arrows in the figure indicate the suggested locations and directions of force application on the robot during transportation. It is prohibited to apply force to other parts of the robot during transportation. Otherwise, the robot may be damaged.

5.4.2 Handling

- The robot and control cab are made of precision components, so they shall be protected from excessive shock and vibration during transportation;
- In order to ensure safe handling and installation, all obstacles shall be removed in advance to keep the passage clear;
- The environmental conditions under which the robot and control cab are handled shall conform to the storage conditions for each component as specified in 0.



Danger

All power of the robot shall be turned off during transportation.

5.4.2.1 Risk of tipping

When the robot is standing still without being fastened to the foundation, the robot shall be enclosed in the bottom liners. In this case, the robot is unstable, and any movements may displace or tilt the center of gravity, and even cause the robot to tip over.

5.4.2.2 Transportation dimensions

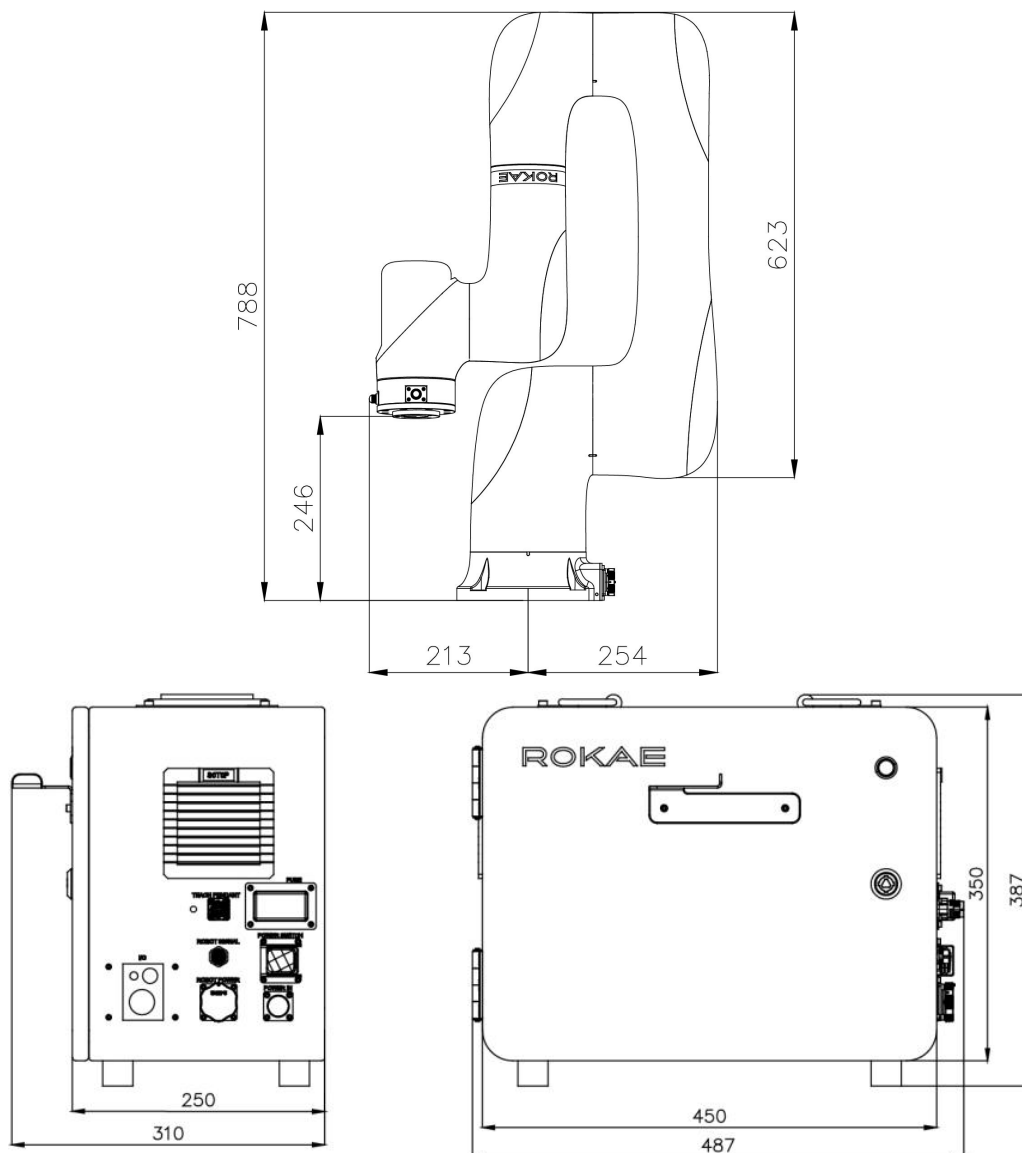

5.5 Installation

5.5.1 Inspection before installation

Personnel who install and operate the robot must have the necessary knowledge for the installation, maintenance, and repair of mechanical and electronic equipment, and must comply with all the relevant national and local regulations.

Check the prerequisites for installation

| No. | Operation |
|-----|---|
| 1 | Visually inspect the robot to confirm that it is not damaged. |
| 2 | Make sure that the intended operating conditions of the robot conform to those specified in this section. |
| 3 | Make sure that the installation conditions comply with the requirements. |
| 4 | Make sure that the storage conditions comply with the requirements if the robot is not installed immediately. |
| 5 | When these prerequisites are met, install the robot as described in the next section. |

5.5.2 Installation of robot and control cab

The control cab is floor mounted type. The following precautions shall be noted during installation.

- In order to realize effective heat dissipation and avoid overheating of the control system, install the control cab in a place with the free space of no less than 300 mm in the front and rear and no less than 150 mm on the left and right for proper cooling, and do not block the vents on the left and right sides of the control cab.
- Make sure that the bending radius of the relay cable connected to the control cab is not less than 75 mm and the plugging distance is not less than 170 mm.

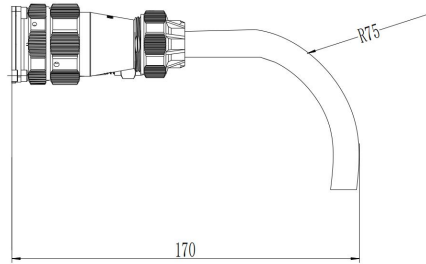



Danger

The control cab contains high-voltage components. Unauthorized personnel are strictly prohibited from opening the cab enclosure. Otherwise, severe or even fatal injuries may occur.

5.5.2.1 Installation and fixing

| Mounting Parts | Specifications | Bracket installation |
|-------------------------------|--|----------------------|
| Hexagon socket head cap screw | M8×30 (Grade 12.9) ×4 | √ |
| Mounting seat | Mounting plate thickness: 25 mm or above | √ |

Note:

- No insulating layer is allowed between the fixing plate/mounting seat and the manipulator/concrete.
- "√" indicates that the item is required for the installation.
- The fixing rigidity of the mounting bracket shall not be lower than that of the robot fixing plate and the foundation.

The robot fixing modes and parameters are shown in the figure below:

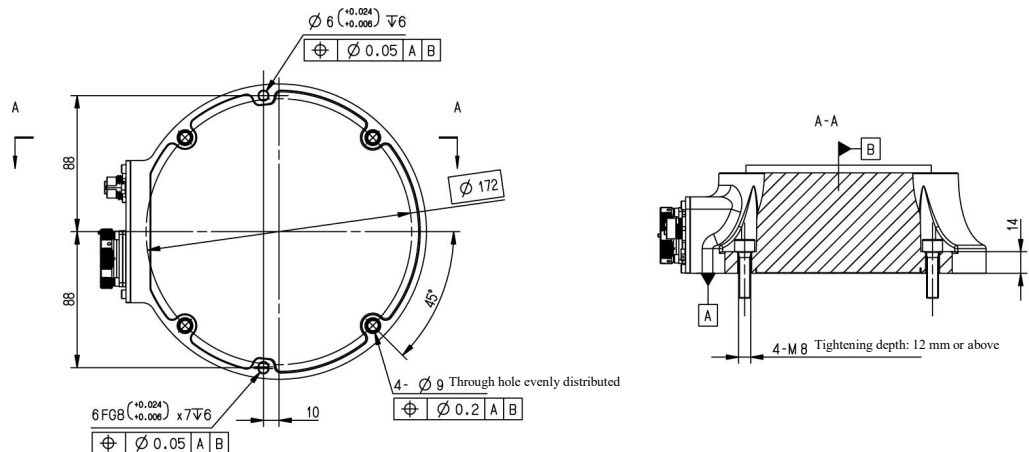

Put pins in the reserved cylindrical pin holes for accurate positioning. Then use four M8×30 hexagon socket head cap screws (strength grade 12.9) to fix the robot's base on the bracket.

The control cab fixing modes and parameters are shown in the figure below:

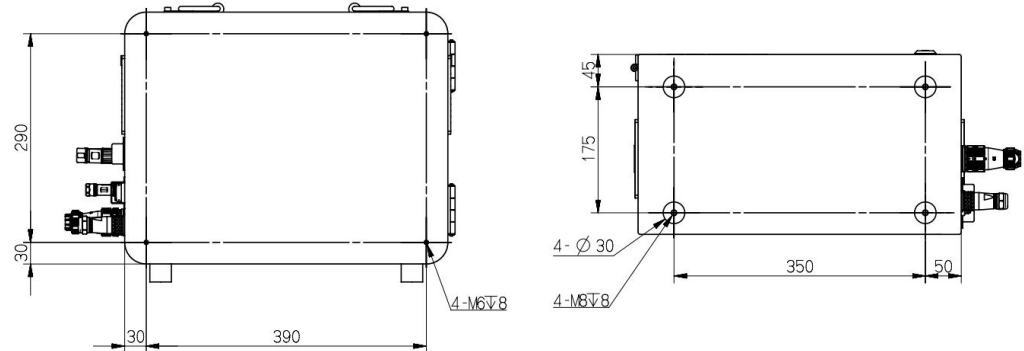

There are four M6 threaded holes in 8 mm depth on the back of the control cab and four M8 threaded holes in M8 depth at the bottom. The fixing mode shall be chosen according to the operating environment.

5.5.2.2 Robot support reaction force

After the robot is installed, its mounting base will generate a large support reaction force due to the static force and dynamic force of the robot, as shown in the figure below. Therefore, the robot base must be able to bear this force.

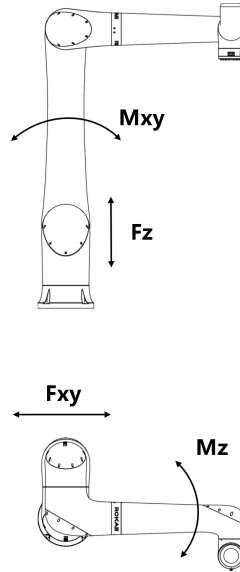

| Force | Maximum | Unit |
|-------|---------|------|
| Fxy | 1750 | N |
| Fz | 2329 | N |
| Mxy | 999 | N·m |
| Mz | 847 | N·m |

i Notes

The above force and torque are the limit values that may appear during the motion of the robot. The limit values occur rarely and cannot be reached at the same time.

5.5.3 Flange

To ensure the accurate positioning of the EOAT, the reserved $\Phi 6$ pin holes shall be used. There are four M6 threaded holes on the end flange of the robot to attach the EOAT to the flange. The M6 screws must be tightened with a torque of 15 N.m. See the figure below for the detailed dimensions.

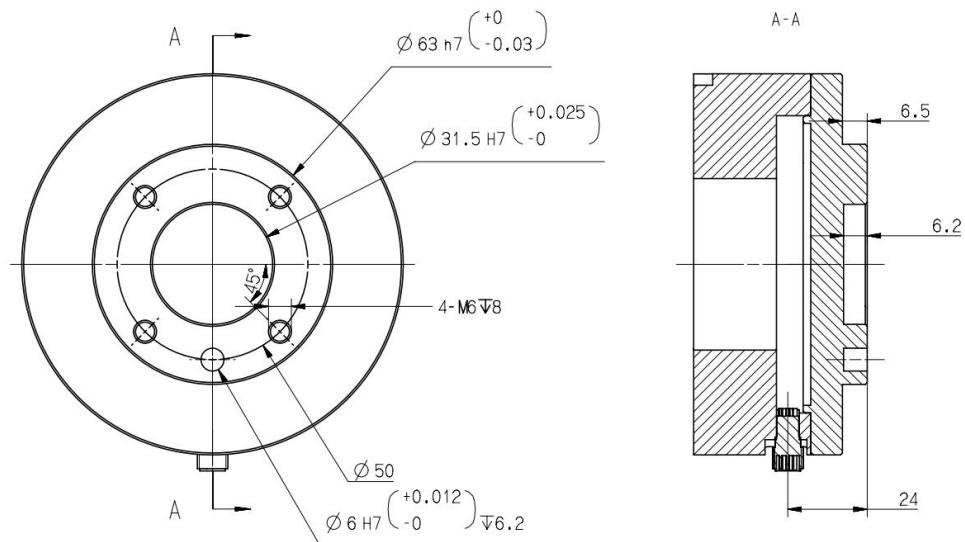

Warning

- The EOAT shall be properly secured in place to prevent its range of motion from overlapping with the robot's working space.
- The length of M6 screws on the installed EOAT shall not exceed the length of thread indicated in the figure to avoid any irreparable damage.
- The EOAT shall operate safely without any detached parts to cause dangers.

6 Electrical connection

6.1 Control cab port

6.1.1 Panel port

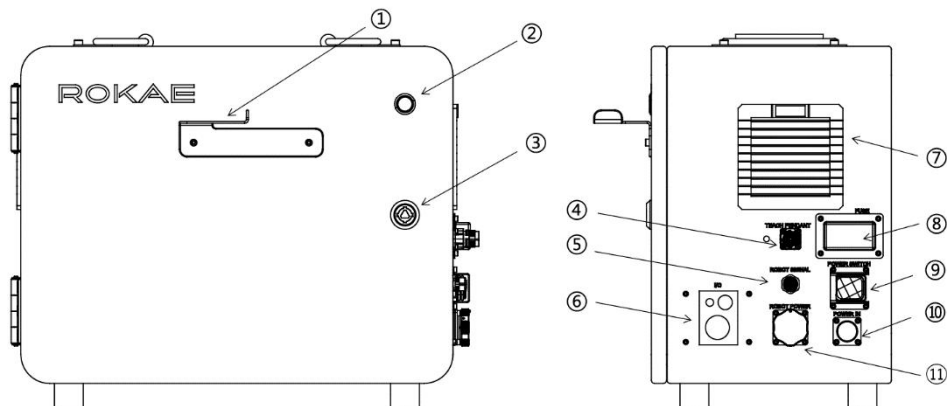

The panel is described as follows:

| No. | Description |
|-----|--|
| ① | Teach Pendant hanger, used to hang the Teach Pendant and assembled by the user |
| ② | Power indicator, at on state after the control cab is powered normally and the power switch is turned on |
| ③ | Door lock |
| ④ | Teach Pendant port, marked as "TEACH PENDANT" |
| ⑤ | Signal relay cable port, marked as "ROBOT SIGNAL" |
| ⑥ | User cable outlet, marked as "I/O" |
| ⑦ | Vent |
| ⑧ | Fuse, marked as "FUSE" |
| ⑨ | Control cab power switch, marked as "POWER SWITCH" |
| ⑩ | Control cab power cable port, marked as "POWER IN" |
| ⑪ | Power relay cable port, marked as "ROBOT POWER" |

Enlarged view of port at side of the panel

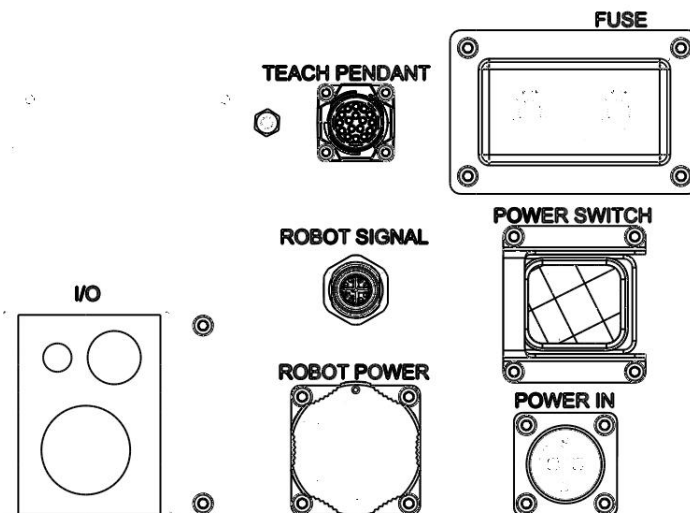

6.1.2 External port

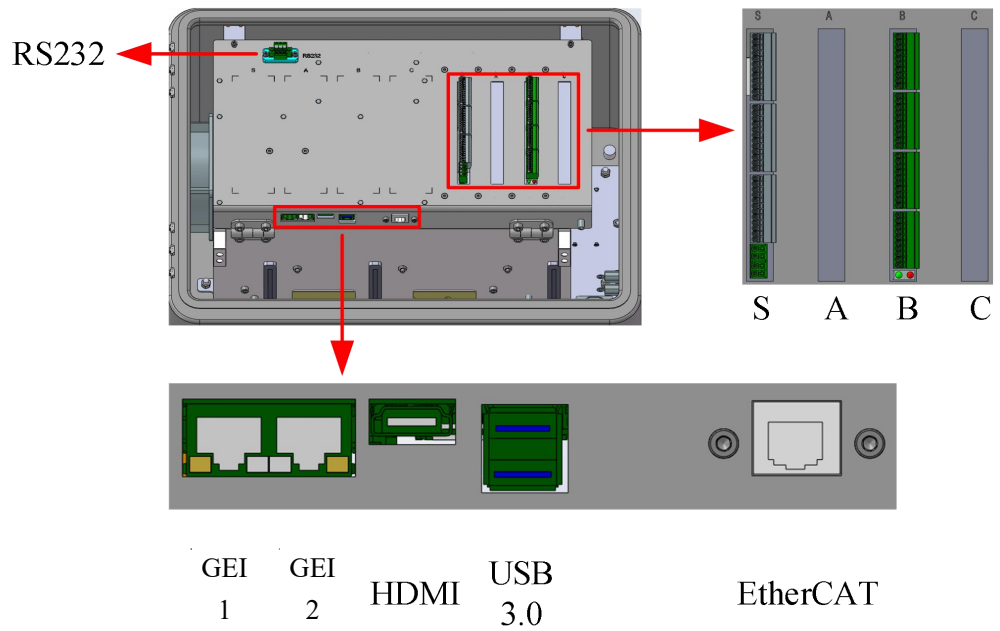

| Mark | Description |
|-------------------|---|
| RS232 | Serial communication port, available for users |
| GEI 1 | Gigabit Ethernet port, special for Teach Pendant, but unavailable for users |
| GEI 2 | Gigabit Ethernet port, available for users |
| USB3.0 | USB3.0 port, used for internal debugging and data import/export |
| HDMI | Display port |
| ECAT network port | Used for EtherCAT expansion communication |
| S | Safety I/O port, standard, immutable |
| A | Vacant in the standard control cab, and optional for an incremental encoder signal acquisition module or a general-purpose digital I/O module or an analog voltage/current I/O module |
| B | General-purpose digital I/O port, standard, immutable |
| C | Vacant in the standard control cab, and optional for a general-purpose digital I/O module or an analog voltage/current I/O module |

 **Danger**

- The control cab contains high-voltage components, so non-professionals shall not open the control cab door with electricity.
- Before opening the front door of control cab for wiring, the user shall power off the control cab. After wiring, he/she shall close the front door before powering on the control cab.
- Live operation/hot-line job may cause damage to the components, even severe or fatal personal injuries.

 **Notes**

The safety I/O port and general-purpose digital I/O port use spring pluggable terminals. When the plugging is not smooth, it is required to check the terminal crimping and avoid brute plugging.

6.1.2.1 Description of safety I/O ports

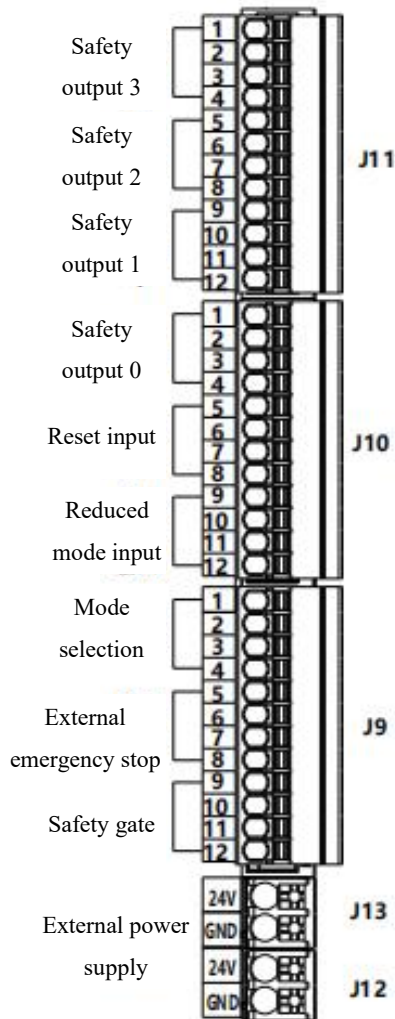

Each group of safety input or safety output signals is dual-channel redundant, so each group contains two inputs/outputs, namely "Loop 1" and "Loop 2", with a total of 4 terminals. Definition of pins:

| No. | Function Definition | Description |
|------|----------------------------|--|
| J9-1 | Mode selection AP | Automatic mode for its short circuit and |
| J9-2 | Mode selection AN | Manual mode for its open circuit |
| J9-3 | Mode selection BP | Automatic mode for its short circuit and |
| J9-4 | Mode selection BN | Manual mode for its open circuit |
| J9-5 | External emergency stop AP | External emergency stop loop 2, |
| J9-6 | External emergency stop AN | short-circuited when not in use |
| J9-7 | External emergency stop BP | External emergency stop loop 1, |

| | | |
|---------|----------------------------|--|
| J9-8 | External emergency stop BN | short-circuited when not in use |
| J9-9 | Safety gate AP | Safety gate loop 2, short-circuited when not in use |
| J9-10 | Safety gate AN | |
| J9-11 | Safety gate BP | |
| J9-12 | Safety gate BN | Safety gate loop 1, short-circuited when not in use |
| J10-1 | Safety output 1AP | GND |
| J10-2 | Safety output 1AN | Output 0 or 24 V depending on the bound safety function |
| J10-3 | Safety output 1BP | GND |
| J10-4 | Safety output 1BN | Output 0 or 24 V depending on the bound safety function |
| J10-5 | Reset input AP | Reset input, reset enabled for its short circuit, or reset disabled for its open circuit |
| J10-6 | Reset input AN | |
| J10-7 | Reset input BP | Reset input, reset enabled for its short circuit, or reset disabled for its open circuit |
| J10-8 | Reset input BN | |
| J10-9 | Reduced mode AP | Reduced mode input, short-circuited when not in use |
| J10-10 | Reduced mode AN | |
| J10-11 | Reduced mode BP | |
| J10-12 | Reduced mode BN | Reduced mode input, short-circuited when not in use |
| J11-1 | Safety output 3AP | GND |
| J11-2 | Safety output 3AN | Output 0 or 24 V depending on the bound safety function |
| J11-3 | Safety output 3BP | GND |
| J11-4 | Safety output 3BN | Output 0 or 24 V depending on the bound safety function |
| J11-5 | Safety output 2AP | GND |
| J11-6 | Safety output 2AN | Output 0 or 24 V depending on the bound safety function |
| J11-7 | Safety output 2BP | GND |
| J11-8 | Safety output 2BN | Output 0 or 24 V depending on the bound safety function |
| J11-9 | Safety output 1AP | GND |
| J11-10 | Safety output 1AN | Output 0 or 24 V depending on the bound safety function |
| J11-11 | Safety output 1BP | GND |
| J11-12 | Safety output 1BN | Output 0 or 24 V depending on the bound safety function |
| J12-J13 | External power supply | Total current of two external power supplies: less than 2A |

For J9, J10, and J11, we recommend using the E0308 tubular insulated terminals.

For J12 and J13, we recommend using the E0508 tubular insulated terminals.

● Description of safety input loop ports

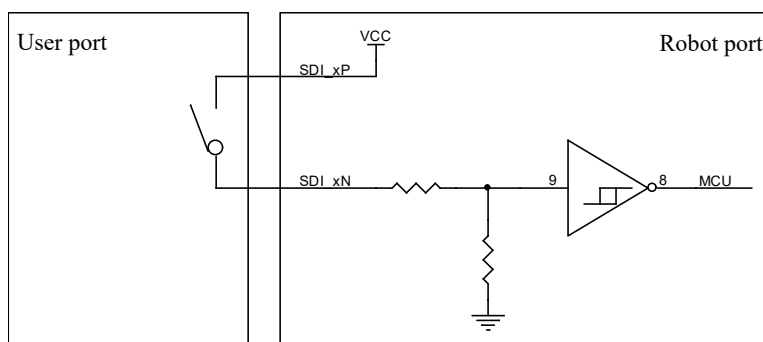

The principle of both loops is the same, and 24 VDC signals are supported.

When wiring, if the safety signals 1AP and 1AN, 1BP and 1BN are short-circuited at the same time, the safety input is valid, and if they are open-circuited at the same time, the safety input is invalid, and the others are abnormal state.

| Item | Parameter |
|-----------------|-----------------|
| Input current | ≤50 mA per loop |
| Wire resistance | ≤15 Ω per loop |
| Quantity | 5 |

● Description of safety output loop ports

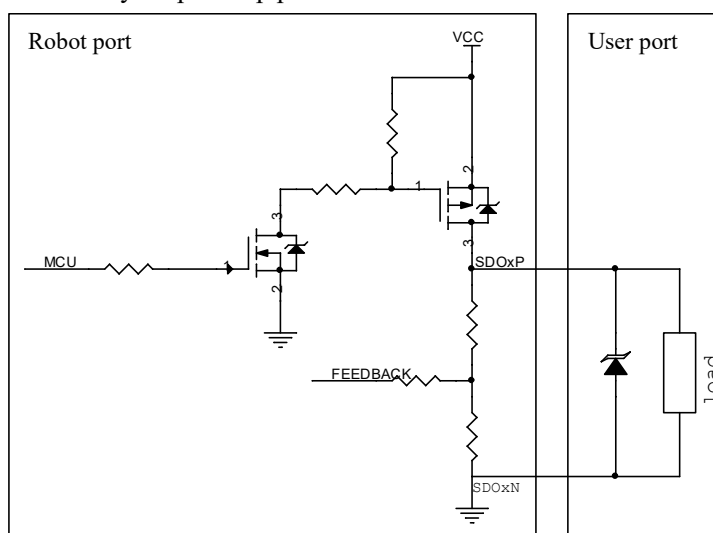

Notes

We highly recommend connecting a freewheeling diode in parallel at both ends of inductive loads!

The safety output loop uses MOSFET output and re-collects the voltage of the MOSFET. The principle of two loops is the same, and 24 VDC signals are supported. When the output signal is valid, a voltage of 24 VDC is generated between the SDOxP and SDOxN.

| Item | Parameter |
|---------------|---|
| Type | Semiconductor output |
| Voltage range | High level: 20 VDC to 30 VDC; low level: -5 VDC to +5 VDC |
| Drive current | 100 mA per circuit |
| Quantity | 4 |

6.1.2.2 Description of general-purpose digital I/O ports

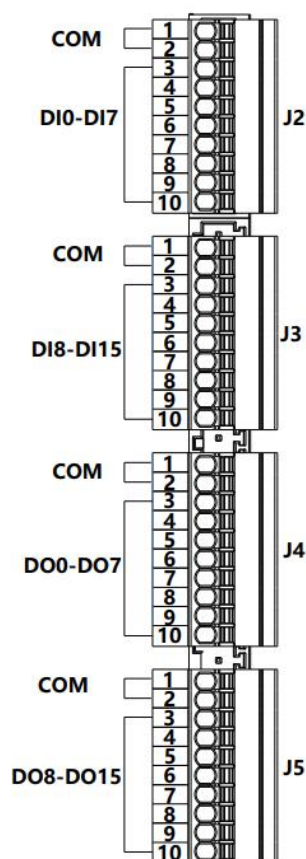

The control cab is equipped with 16 general-purpose digital inputs and 16 general-purpose digital outputs as standard, with pin definition as follows:

| No. | Function Definition | Description |
|-------|---------------------|----------------------------|
| J2-1 | Common port | DI power, provided on site |
| J2-2 | Common port | |
| J2-3 | DI0 | Custom |
| J2-4 | DI1 | Custom |
| J2-5 | DI2 | Custom |
| J2-6 | DI3 | Custom |
| J2-7 | DI4 | Custom |
| J2-8 | DI5 | Custom |
| J2-9 | DI6 | Custom |
| J2-10 | DI7 | Custom |
| J3-1 | Common port | DI power, provided on site |
| J3-2 | Common port | |
| J3-3 | DI8 | Custom |
| J3-4 | DI9 | Custom |
| J3-5 | DI10 | Custom |
| J3-6 | DI11 | Custom |
| J3-7 | DI12 | Custom |
| J3-8 | DI13 | Custom |
| J3-9 | DI14 | Custom |

| | | |
|-------|-------------|----------------------------|
| J3-10 | DI15 | Custom |
| J4-1 | Common port | DO power, provided on site |
| J4-2 | Common port | |
| J4-3 | DO0 | Custom |
| J4-4 | DO1 | Custom |
| J4-5 | DO2 | Custom |
| J4-6 | DO3 | Custom |
| J4-7 | DO4 | Custom |
| J4-8 | DO5 | Custom |
| J4-9 | DO6 | Custom |
| J4-10 | DO7 | Custom |
| J5-1 | Common port | DO power, provided on site |
| J5-2 | Common port | |
| J5-3 | DO8 | Custom |
| J5-4 | DO9 | Custom |
| J5-5 | DO10 | Custom |
| J5-6 | DO11 | Custom |
| J5-7 | DO12 | Custom |
| J5-8 | DO13 | Custom |
| J5-9 | DO14 | Custom |
| J5-10 | DO15 | Custom |

For J2, J3, J4, and J5, we recommend using the E0308 tubular insulated terminals.

- Description of general-purpose DI ports

The 16 digital inputs include drain and source type. When the input is active high (sink), the PNP level signals are available, and when the input is active low (source), the NPN type level signals are available:

| Item | Parameter |
|---------------------|---|
| Input voltage range | 0 VDC to 28 VDC |
| Turn-on voltage | Common port 0 VDC: high input, 15 VDC to 28 VDC Common port 24 VDC: low input, 0 VDC to 10 VDC |
| Turn-off voltage | Common port 0 VDC: high input, 0 VDC to 5 VDC Common port 24 VDC: low input, 19 VDC to 24 VDC |
| Input impedance | 7.5 kΩ |

The electrical principles in the two modes are shown below.

When the common port is 0 VDC, the PNP input signals are available, as shown below:

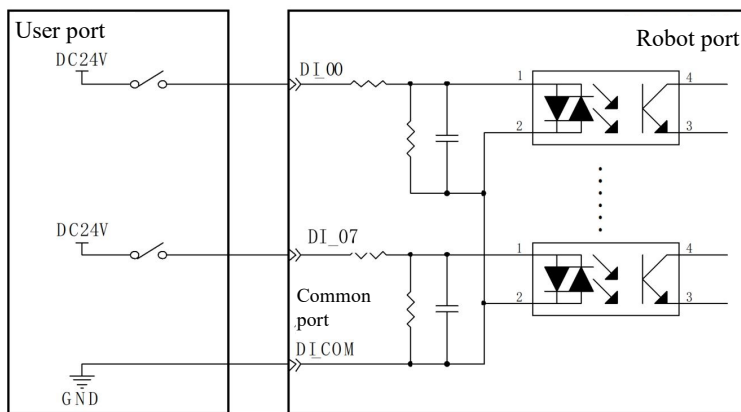

When the common port is 24 VDC, the NPN input signals are available, as shown below:

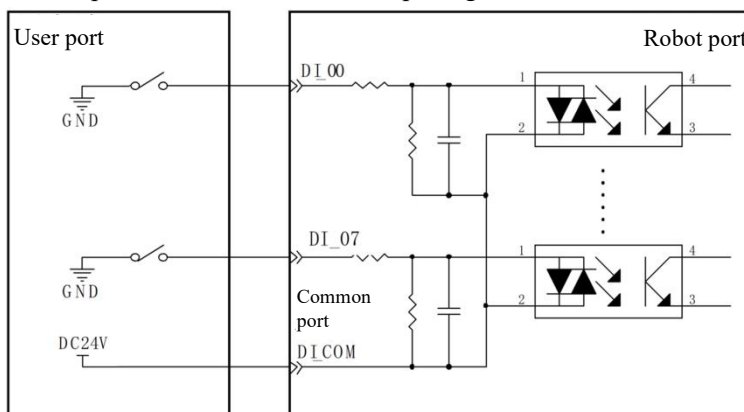

● Description of general-purpose DO ports

The 16 digital outputs include drain and source type, which can be configured to active high and active low, and the output parameters are as follows:

| Item | Parameter |
|--------------------|---|
| Load voltage range | ≤28 VDC |
| Rated load current | Max. 300 mA (continuous load current cannot exceed the maximum) |
| Output impedance | ≤2.5 Ω |
| Drain current | Max. 5 uA |

The electrical principles in the two modes are shown below.

When the output is active low, the DO_COM (common port) is connected to 0 VDC, as shown below.

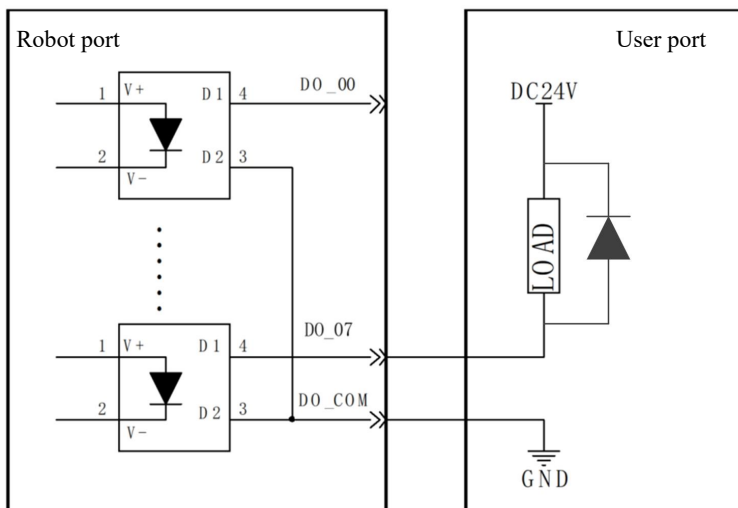

When the output is active high, the DO_COM (common port) is connected to 24 VDC, as shown below.

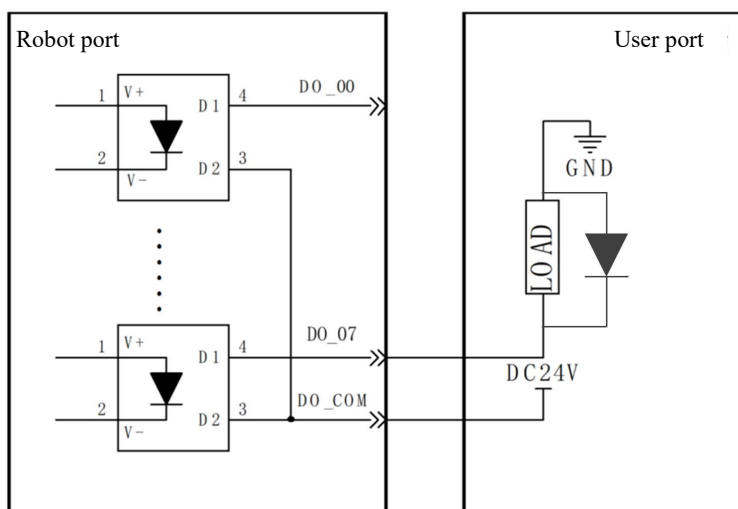

 **Notes**

We highly recommend connecting a freewheeling diode in parallel at both ends of inductive loads.

6.2 Description of EOAT I/O ports

The end flange of the robot is equipped with a direct teach button and an EOAT I/O port. As shown in the figure, ① is a direct teach button, and ② is an EOAT I/O port.

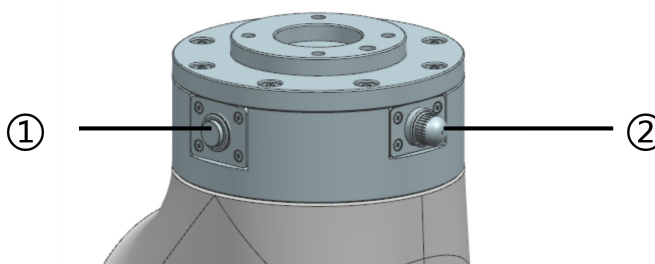

The Direct Teach mode can be enabled by pressing and holding the direct teach button.

The EOAT I/O port is an electrical expansion port for end effector and is an M8 circular connector for M8-FS-8CON-PVC-2.0 industrial cables.

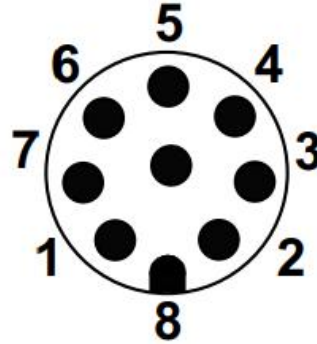

| S/N | Cable Color | Definition |
|-----|-------------|-------------|
| 1 | White | AI_0/RS485+ |
| 2 | Brown | AI_1/RS485- |
| 3 | Green | DI_1 |
| 4 | Yellow | DI_0 |
| 5 | Gray | 0V/12V/24V |
| 6 | Black | DO_1 |
| 7 | Blue | DO_0 |
| 8 | Red | GND |

6.2.1 Special-purpose EOAT I/O

A special-purpose gripper is optional for the robot as the end effector, with the electrical and special-purpose communication ports integrated into the connector.

6.2.2 EOAT power output

When the user uses the gripper and sensor as robot EOAT, the M8 connector provides power with electrical specifications as follows:

| | Minimum | Typical | Maximum | Unit |
|---------------------|---------|---------|---------|------|
| EOAT supply voltage | 12 | 24 | 24.8 | V |
| EOAT supply current | — | 1 | 2 | A |

 **Warning**
 The digital outputs in the EOAT are not current-limited. Overriding the specifications can cause permanent damage.

 **Notes**
 We highly recommend connecting a freewheeling diode in parallel at both ends of inductive loads.

6.2.3 EOAT digital outputs

There are 2 EOAT digital outputs, which can be configured to NPN or PNP through HMI. In PNP mode, the EOAT power output shall be valid, and the PNP output level shall be consistent with the EOAT supply voltage.

The electrical specifications of the digital output NPN mode are as follows:

| Item | Minimum | Typical | Maximum | Unit |
|---|---------|---------|---------|------|
| Operating voltage | -0.5 | - | 26 | V |
| Sink current | 0 | - | 150 | mA |
| Voltage in output active (sink current: 200 mA) | 0 | 0.05 | 0.2 | V |

Wiring diagram in digital output NPN mode

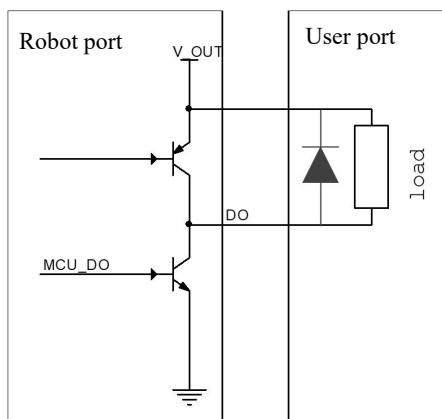



The electrical specifications of the digital output PNP mode are as follows:

| Item | Minimum | Typical | Maximum | Unit |
|---|---------|---------|---------|------|
| Operating voltage | 0 | - | 26 | V |
| Sink current | 0 | - | 150 | mA |
| Voltage in output active (source current: 200 mA) | 0 | 12/24 | 26 | V |

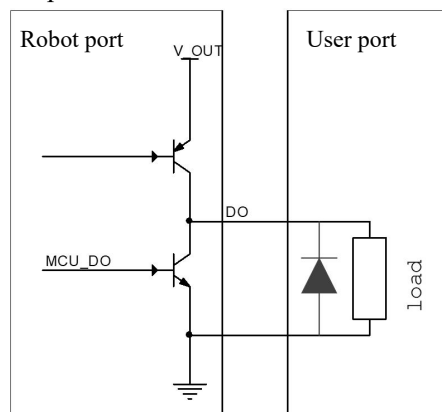
Wiring diagram in digital output PNP mode



 **Warning**
 The digital outputs in the EOAT are not current-limited. Overriding the specifications can cause permanent damage.

 **Notes**
 We highly recommend connecting a freewheeling diode in parallel at both ends of inductive loads.

6.2.4 EOAT digital inputs

There are 2 EOAT digital inputs, which are only available for NPN mode, with weak pull-high function. The digital inputs are always invalid in hover state, with electrical characteristics as follows:

| Item | Minimum | Typical | Maximum | Unit |
|------------------------|---------|---------|---------|------------|
| Input voltage | 0 | - | 26 | V |
| Logical active level | 0 | - | 3 | V |
| Logical inactive level | 8 | - | 26 | V |
| Input resistance | - | 47 | - | k Ω |

Diagram of connecting 1 simple switch to the user port:

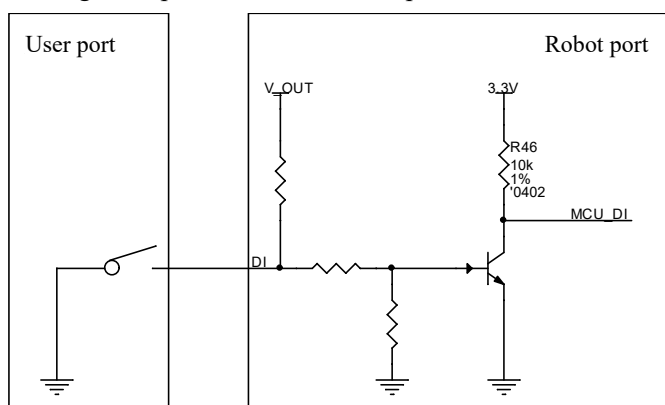

6.2.5 EOAT analog inputs

The EOAT analog inputs are available for both voltage and current modes through the HMI.

The parameters of analog voltage inputs are as follows:

| Item | Minimum | Typical | Maximum | Unit |
|----------------------------------|---------|---------|---------|------------|
| Input voltage in voltage mode | 0 | - | 26 | V |
| Input resistance in voltage mode | - | 22.4 | - | k Ω |
| Resolution | - | 12 | - | bit |

Wiring diagram of analog voltage input port

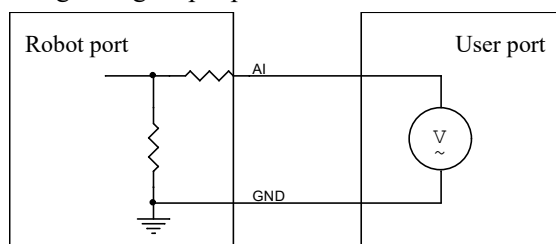

The parameters of analog current inputs are as follows:

| Item | Minimum | Typical | Maximum | Unit |
|----------------------------------|---------|---------|---------|----------|
| Input current in current mode | 4 | - | 20 | mA |
| Input voltage in current mode | 0 | - | 6 | V |
| Input resistance in current mode | - | 240 | - | Ω |
| Resolution | - | 12 | - | bit |

Wiring diagram of analog current input port

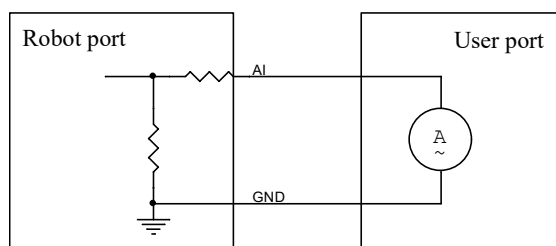

6.2.6 EOAT communication

The EOAT supports RS485 bus communication and follows the Modbus communication protocol.

The communication baud rate includes 9600, 19200, 38400, 57600, 115200, etc.

The EOAT communication port supports Modbus transparent transmission, the EtherCAT communication is adopted between the IPC and the EOAT, and the message transmission delay does not exceed 3 ms when the EOAT performs RS485 communication with the end effector.

6.3 Connection system

A complete xMate CR7-C electrical connection system is shown in the figure below:

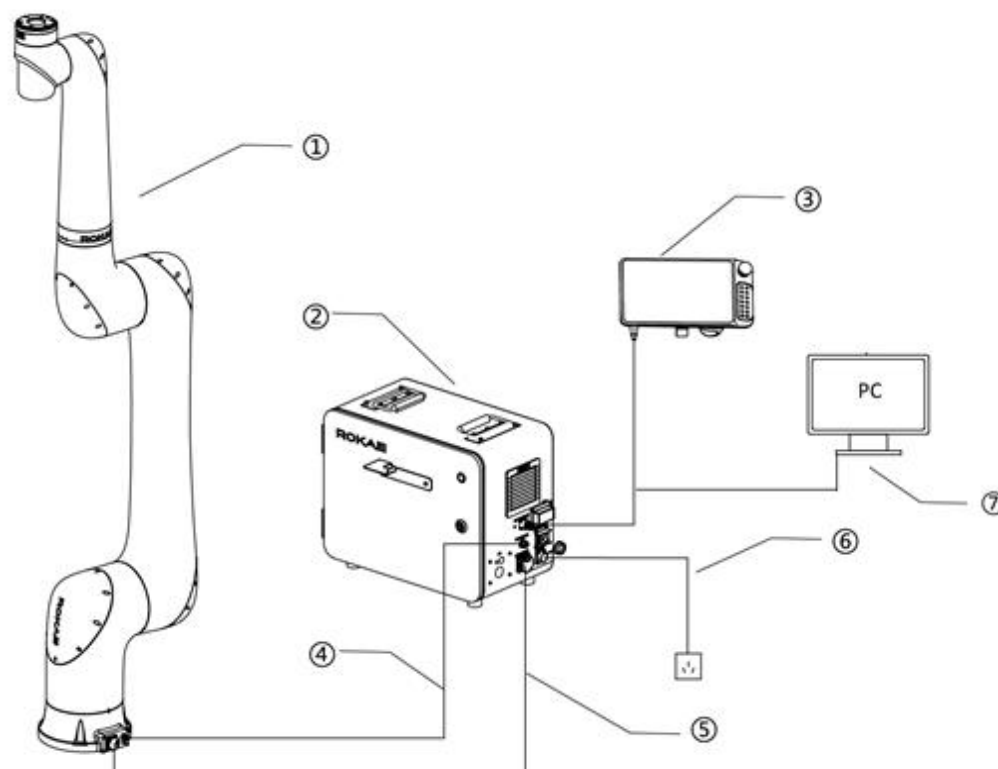

| S/N | Name |
|-----|---|
| ① | Manipulator |
| ② | Control cab |
| ③ | Teach Pendant |
| ④ | Signal relay cable |
| ⑤ | Power relay cable |
| ⑥ | Control cab power cable |
| ⑦* | Personal computer with a network cable port |

*Note: ⑦ and ③ share the same electrical port, so they cannot be connected at the same time. The personal computer with a network cable port is usually used for debugging, the practical application is connected in the same way of Teach Pendant.



Danger

Before wiring, it is required to power off the controller and related devices and put the warning symbol (e.g. do not turn on the power). Wiring under power-on conditions is extremely dangerous and may cause electric shock or malfunction of the robot system.

As shown in the figure below, up to 3 padlocks ① can be installed at the sheet metal ③ above the rocker switch ② to prevent others from turning on the switch.

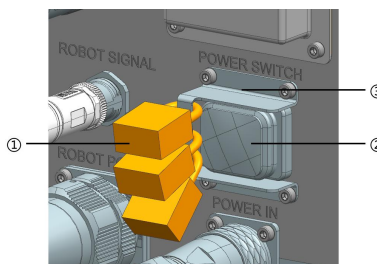

The padlock dimensions are as follows:

| | Specifications | Dimensions (mm) |
|--|----------------|-----------------|
| | L | 20 |
| | W1 | 9.5 |
| | W2 | 19.5 |
| | W3 | 11 |
| | (H) | 11.5 |
| | D | 3.2 |

6.3.1 Connection of the Teach Pendant

Connect the air plug of the Teach Pendant cable to the socket marked "TEACH PENDANT" on the side of the control cab.

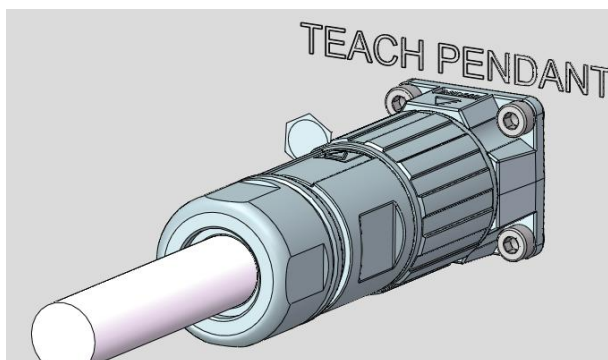

6.3.2 Connection of the manipulator

There are two connecting wires between the control cab and the manipulator, namely the power relay cable and the signal relay cable, which are 6 m flexible cables as standard. The mass of the power and signal relay cables is about 1.7 kg and 0.6 kg, respectively.



Connect the socket marked with the "ROBOT POWER" on the side of the control cab with the socket marked with ① at the manipulator base using a power relay cable, and connect the socket marked with the "ROBOT SIGNAL" on the side of the control cab with the socket marked with ② at the manipulator base using a signal relay cable.

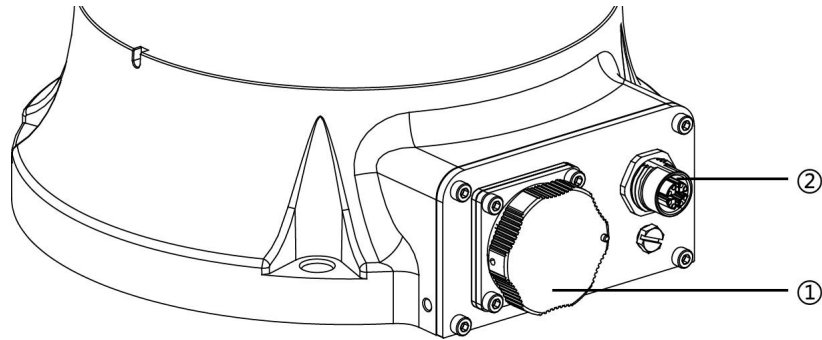

6.3.3 Connection of the control cab power supply

The control cab is provided with a single-phase AC power supply with parameters as shown in 4.3. The user shall provide a power supply that meets the relevant parameter requirements. The robot is supplied with a 6 m flexible power cable as standard, with a plug (on one end) that matches the socket marked "POWER IN" on the side of the control cab and a 10 A grounding single-phase three-pin plug (on the other). The mass of the AC power cable is about 1.1 kg.



Warning

For overcurrent protection of the control cab power supply, the user shall cautiously choose a suitable overcurrent protector according to the rated power of the purchased control cab.

The user shall ensure good grounding.



Notes

All connectors shall be plugged in carefully and gently. If difficult, you shall check whether the pins in the connector are skewed, and if any abnormalities are found, they shall be corrected to avoid damage to the connectors.

6.3.4 Custom wiring

The custom wiring is suitable for the following:

- Custom I/O signals (including safety I/O and general-purpose digital I/O)
- Custom network/communication signals



Warning

The wiring must be carried out by the certified workers or qualified personnel with relevant knowledge. Otherwise, it may result in personal injury or equipment malfunction.

The custom I/O signal (including safety I/O and general-purpose digital I/O) and network/communication signals shall pass out of the control cab from the foam marked with "I/O". The diameter of the pre-opened holes in the foam is shown below:

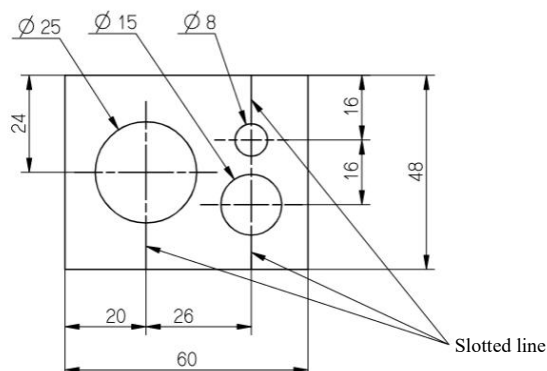

For wiring in the cab, it is recommended to follow the path indicated the arrow in the figure below, with cable binding brackets along the path, and fix the cable with cable ties to keep it neat and clean.

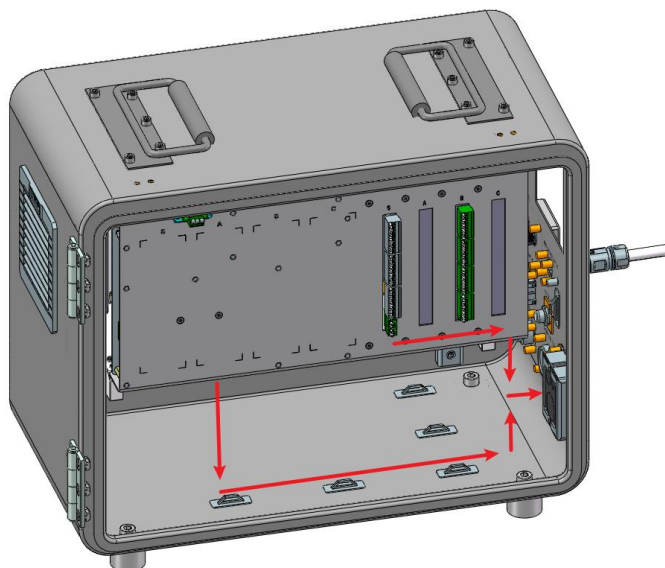

6.3.5 Grounding instructions

The user shall properly ground the manipulator and the control cab with terminals according to the actual on-site situations and the available space to achieve D-type grounding (the grounding resistance shall be less than 100 Ω).

The control cab can be grounded by the grounding terminal of the power cable, and the grounding position of the robot body is shown in the figure below.

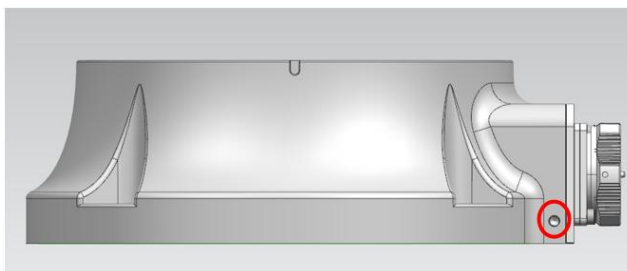

7 Quick Operation

7.1 Power on

After completing the above wiring, you shall check and confirm the following contents before powering on:

- The power connector of the control cab is well plugged.
- The control cab is properly connected with the robot.
- The control cab is properly connected with the Teach Pendant.
- The power switch of the control cab is in the off state when power supply is not turned on.
- The emergency stop switch of the Teach Pendant is in the release state.
- The power supply of the control cab provided by the user meets the requirements and operates normally.
- The user ensures that the robot does not collide with the surrounding personnel or equipment.
- The control cab is firmly fixed.
- The manipulator is firmly fixed.

After confirming without error, press the rocker switch marked with "POWER SWITCH" on the side of the control cab, the white power indicator on the control cab door will be on, and the system will be powered on and started normally.

If everything is normal, the system will display a welcome interface on the Teach Pendant after startup. If an alarm occurs after the startup or the system cannot be started, you shall:

- Turn off the power switch and recheck the wiring.
- Contact the technical support.

7.2 Confirmation of the emergency stop

After startup, press the emergency stop button on the Teach Pendant to check if an emergency stop alarm of the control system is triggered. Then release the emergency stop button to check if the emergency stop alarm is successfully cleared and the system returns to normal.

After confirming the normal performance of the emergency stop, you can conduct configuration or programming on the robot.

7.3 Programming and usage

For more information about the usage, programming, and parameter settings of the robot operating system, refer to the *xCore Robot Control System User Manual*.

8 Maintenance

8.1 Introduction

Please read the "Maintenance safety" section, this manual, and other related documents carefully to gain a full understanding of the safe maintenance methods before maintenance.

8.2 Maintenance safety



Warning

- The maintenance procedures shall be followed strictly to avoid random disassembly.
- The maintenance shall only be performed by designated professionals.
- Without accepting training, you shall stay away from the robot when it is powered on. Also, you shall do not enter the robot's range of motion. Even if a powered-on robot seems to stop, it may move accidentally and cause serious safety problems.
- It is required to confirm the action of the robot after replacing the parts outside the safety fence. Otherwise, the robot may perform unexpected actions and cause serious safety problems.
- Before robot's normal operation, the emergency stop switch and the safety fence switch shall function properly. Otherwise, the safety functions cannot be guaranteed in the event of an emergency, and serious injury or damage may occur, which is extremely dangerous.

8.3 Maintenance schedule

The robot must be maintained regularly to ensure high performance over a long period of time. The maintenance personnel must prepare a maintenance schedule and implement such schedule strictly.

8.4 Inspection

| No. | Item | Position | Interval | | | | |
|-----|---|------------------|----------|---------|----------|----------|--------|
| | | | Daily | 1 month | 3 months | 6 months | 1 year |
| 1 | Check the appearance for damage | Robot appearance | | | | | |
| | | External cables | | | | | |
| 2 | Check the control cab and robot connector for looseness | Control cab | | | | | |
| | | Manipulator | | | | | |

8.5 Cleaning



Warning

Improperly using the liquid detergents or incorrectly turning off the power supply may cause electric shock and result in serious injury or death.



Warning

The cleaning shall be performed only after the robot is completely powered off.

The robot shall not be cleaned with liquid detergents.

The robot shall not be powered on when it is wet.

The following instructions shall be observed when cleaning the robot:

Clean the robot only by trained users.

Do not clean the robot with any chemical solvents, but use a damp cloth that has been wrung out.

Do not apply excessive force to the manipulator during cleaning. Always hold the part that is manually cleaned by hands to avoid overloading the manipulator and causing any damage.

Power on the robot only after all the surfaces are completely dry.



Warning

Improper cleaning may damage the robot.

9 Zero Calibration

This section describes the zero calibration. Only the calibration tools described in this section shall be used during calibration.

9.1 What is a mechanical zero?

The robot is pre-defined with an initial orientation during its design, in which the angle of each joint is zero. From a mechanical viewpoint, the zero orientation is the orientation where a specific angle is formed between adjacent links. From a software viewpoint, since the robot uses the encoder to record the joint angle, the zero orientation refers to the robot's orientation when the servo motor rotates to a specific encoder value. Therefore, the mechanical zero can be explained in two ways:

- From the perspective of the observer, the mechanical zero is the robot's orientation when each joint of the robot moves to a specific position.
- From the perspective of the control system, the mechanical zero is a combination of encoder values.

9.2 What is zero calibration?

The zero is a point of reference for the robot coordinate system, which is essential for the robot to determine its own position. To maximize the absolute positioning accuracy and make the link system properly respond to the position and speed instructions from the control system, a zero calibration must be performed on the robot to bring the mechanical zero as close to the algorithm zero as possible.

More generally, zero calibration is the process of using the pre-designed positioning devices on the mechanical manipulator to rotate the joints of the robot to a specific angle, and notifying the control system to record the value of each joint encoder.

9.3 When is zero calibration required?

A zero calibration must be performed using dedicated calibration tools in the following circumstances:

- The mechanical system parts such as motors and reducers are replaced.
- A violent collision occurs.
- The robot joint is moved by external force with system powering off.

9.4 Zero calibration procedures

The keyway calibration method is adopted from the axis 1 to axis 6 of xMate CR7-C robots. Only one axis can be calibrated at a time, and the specific process is as follows.

Step 1: Calibrate the axis 1

Rotate the axis 1 slowly until the calibration pin ② is aligned with the calibration slot, then insert it into the keyway towards the direction indicated in the figure below and with a special calibration tool. If it cannot be inserted into the keyway of the upper and lower links at the same time, continue to rotate the axis 1 slowly until it is inserted properly. At this time, it is considered that the mechanical zero calibration of axis 1 is finished.

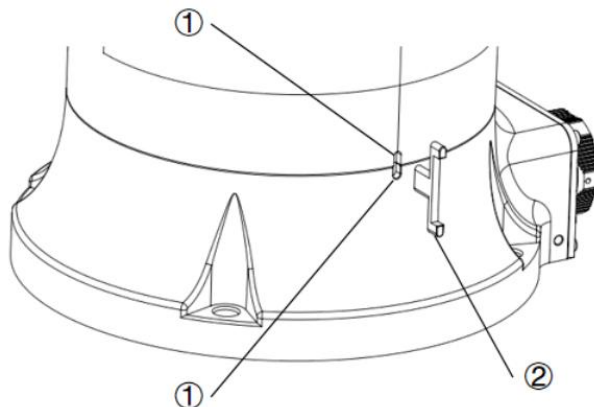



Step 2: Calibrate axes 2, 3, 5, and 6

Calibrate according to step 1.

Step 3: Calibrate the axis 4

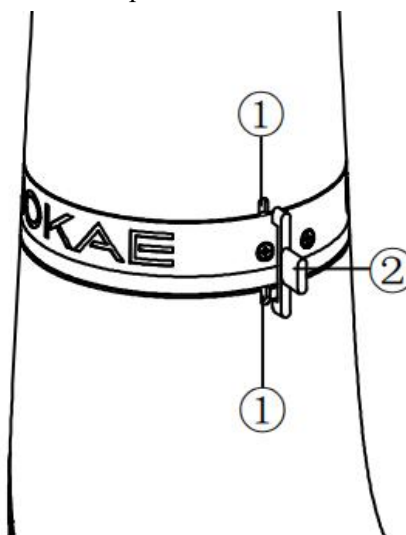
Calibrate the axis 4 according to step 1, but note that the direction of the special calibration tool is opposite to that of step 1.



 **Warning**

After the mechanical zero calibration is finished, the special calibration tool must be removed from the corresponding calibration keyway, and the manipulator status must be inspected to prevent accidents.

10 Decommissioning

10.1 Robot decommissioning

The decommissioning, storage, and disposal of the robot must be performed in compliance with relevant national laws, regulations, and standards.

10.2 Recycling

Contact us for the recycling of robot.

11 Revision History

| Version | Date | Revision History |
|---------|-------------------|------------------|
| A | December 22, 2023 | First release |
| | | |
| | | |

ROKAE



ROKAE

400-010-8700
www.rokae.com
sales@rokae.com